

operation instruction of electronical treadmill

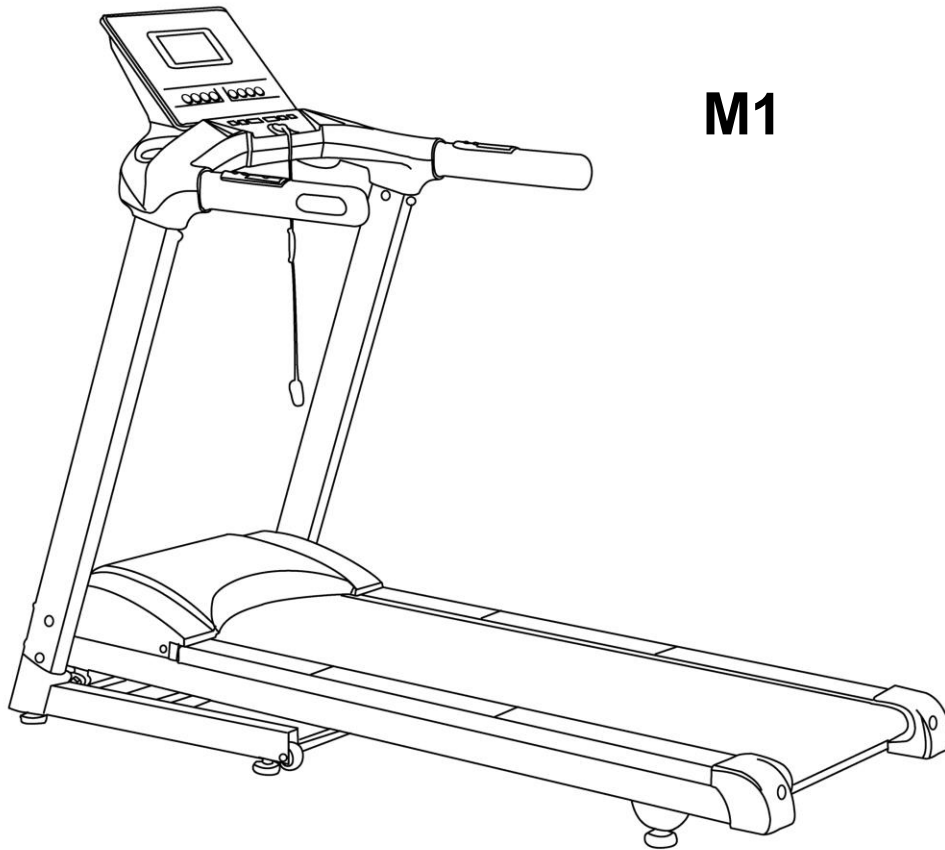

M1

Thank you for choosing our electrical treadmill!

This manual includes how to operate treadmill and safety precautions.

Please read this manual carefully before using the machine! Incorrect using may get damage to your health.

Contents

Important safety precautions.....	2
Main technical parameter.....	3
Diagram	4
Assembly instruction.....	4
Description of display.....	6
Adjustment.....	8
Operation guidance.....	8
Daily maintenance.....	10
Common failure and maintenance	12
Foldable operation.....	13
Chart of safety area.....	14

Important safety precautions



Warning: in order to avoid any injury before using this electrical treadmill please read all instructions and warnings carefully! We won't take the responsibility if the user operates the machine Incorrect.

- 1 Please consult your doctor first before exercising especially for the people whose age is above 35.
- 2 Everyone who uses this machine has the responsibility to read all warnings and precautions.
- 3 Please use this machine according to the manual.
- 4 Put this machine on a flat floor and keep a free space about 2m behind and 0.5m both sides.
- 5 The treadmill should be put inside of room and avoid the moisture
- 6 The treadmill is designed for adults and children (below 12) are not allowed to use it.
- 7 Two or more than two persons are prohibited to run on the treadmill at one time.
- 8 The maximum load of this treadmill is 110kgs.
- 9 Wear suitable clothes when you exercising. For example sports clothes and shoes and so on.
- 10 If more cable needed, please use 3-core cable, 1.5 square millimeter and no longer than 1.5m.
- 11 Power cable should keep away from any heat sources.
- 12 It's forbidden to stop the machine manually (purposely) when you switch off the power. It's not allowed to use the machine when the cable or plug is damaged.
- 13 Please read and test the emergency stop program.
- 14 To ensure your safety, please stand on both sides of the treadmill start pedal.
- 15 The speed of this machine is adjustable. We suggest you should increase the speed slowly.
- 16 The pulse heart rate sensor is not a medical facility. Because there are too many factor to affect its precision.
- 17 This machine should be supervised when it is working. Please switch off when you don't use it.
- 18 It is not allowed to move the machine before you finish assembling the machine.
- 19 It is not allowed to change the inclination of the treadmill by insert something under the machine.
- 20 Please check the parts of the machine regularly.
- 21 It is not allowed to put anything to the hole of the treadmill.
- 22 Dangerous: make sure switch off the power immediately when you finish exercising. Please take off the plug when you take care or maintenance the treadmill. It's forbidden to open the cover of the motor only if granted by the manufacturer.
- 23 Excessive exercise may do damage to your health. If you fell pain or any uncomfortable, please stop exercising immediately.
- 24 As improvements of the technical our company reserves the right of final interpretation, if there are any changes.
- 25 Caution: Please don't put whole body weight on the handrail of the treadmill for a long time, to avoid unnecessary damage.
- 26 Notice: When lubricating the running belt, please add the silicone oil to the middle of the belt, don't be tainted to the edge of running belt on both sides.

Main technical parameter

Input voltage:	AC220V±15% (50Hz or 60Hz)	
Continuous power:	2.5HP	
Working temperature:	5°C-40°C	
Speed range:	0.3-16km/h	
Time display range:	00:00-99:59	
Distance range:	0.000-9.999km	
Calorie display range:	000-999K cal	
Pulse display range:	50-230 per/min	
Running area:	1270mmx420mm	
packing size:	1710mmx775mmx390mm	
Main function:	Speed choice buttons	Support for Mobile devices charged
	Adjustable light LCD display	Heart rate control program
	Shock absorption system	Folding and lay down by buffer
	Automatic varied running program	
	Stereo sound	Touch buttons
		Bluetooth Player
	Built-in MP3 player (for an external U disk)	
Motor:	Noiseless DC motor	
Controller:	PMW controller	
N.W.:	61kgs	
G.W.:	77kgs	
Maximum load:	110kgs	

Diagram

please be familiar with the following parts:

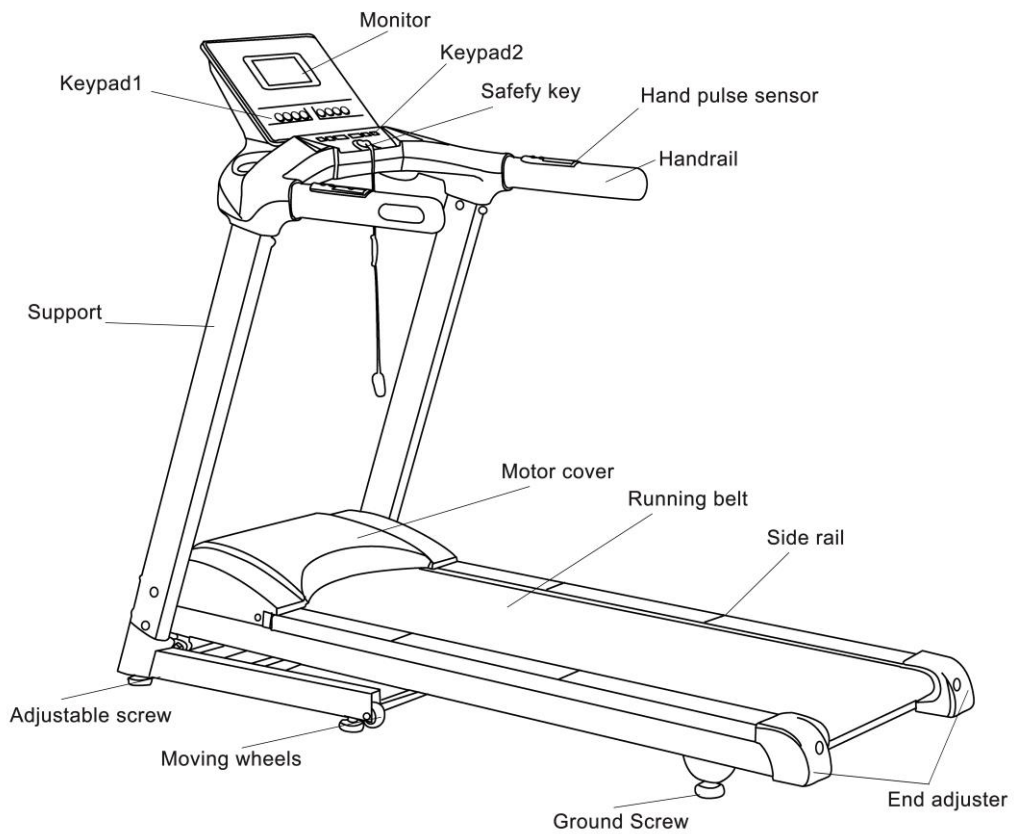

assembly instruction

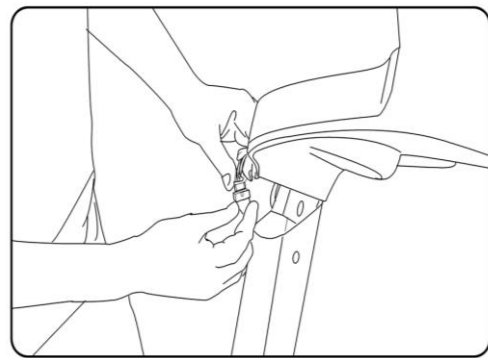
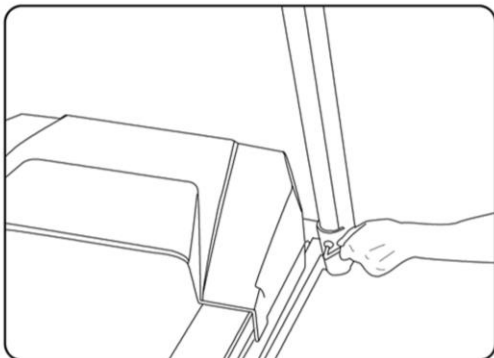

- 1、 Install the side screw on the bottom of the pole.
- 2、 Connect the monitor control lines with the pole control cable.

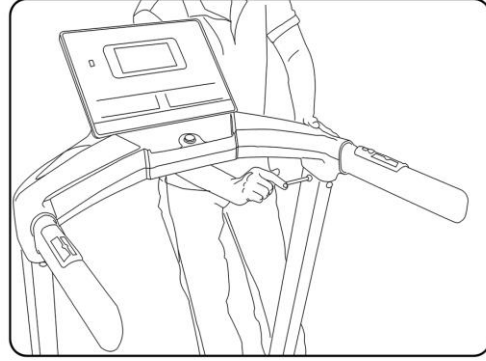

- 3、 Put the monitor in place.
- 4、 Tighten the monitor with the pole by screw, the installation is complete !

NOTE: Install all the screws in place and tighten them one by one!

Description of display

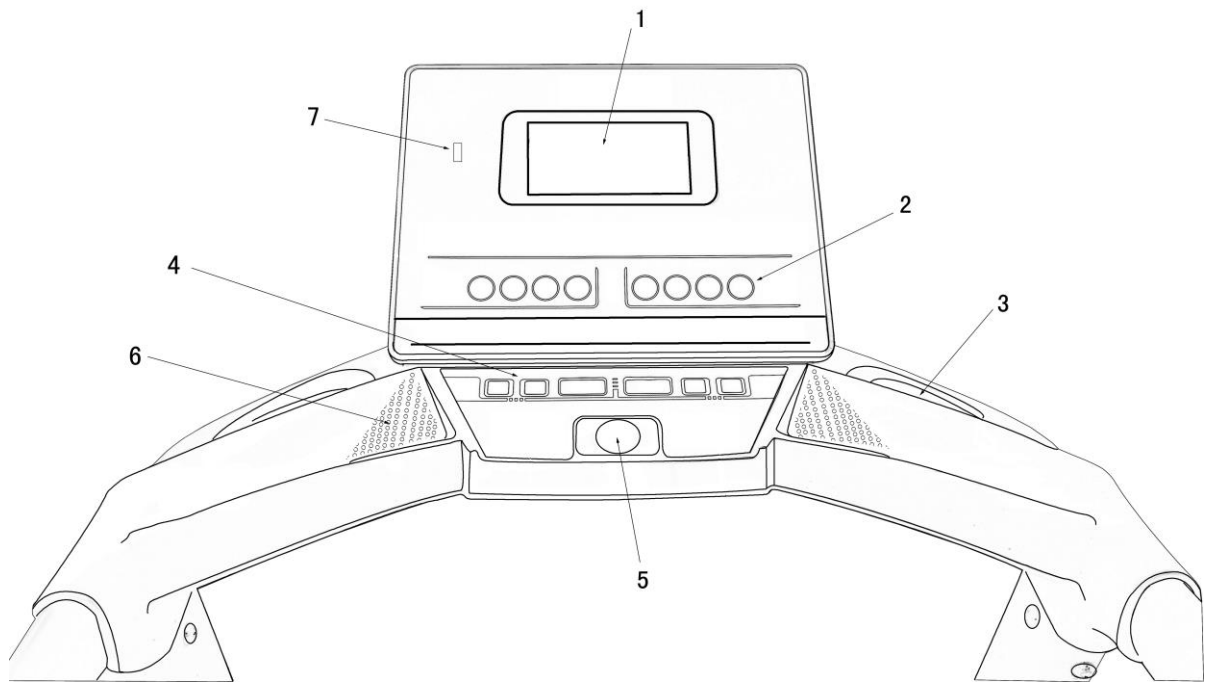

1、LCD Display

2、Key board 1*

3、Cup holder

4、Key board 2*











5、Safety key



6、Speaker

7、USB audio interface

Notice: About Keypad1& Keypad2, please check the key functions excel.

Key functions excel

Key icon	Key functions description
	<p>Program key: In the stopped state while the safety switch is not be pressed, press the program key, the heat display window will show P01---P30.</p>
	<p>Set key: In the stopped state while the safety switch is not be pressed, press the Set key, six windows will twinkle individually and change, press fast & slow key can adjust the setting numerical.</p>
	<p>Speed direct choice 4km/h: When the treadmill is not running under running program, press Speed direct choice button 4, treadmill will run at 4 km / h speed. (Speed direct choice 5,6,8have the same function)</p>
	<p>Play/Pause: This button is MP3 function control button, when insert the U disk with music files, press this button and it will play music, press again can pause the playing .When in Bluetooth connection status, press this button to control the Bluetooth play and pause.</p>
	<p>Sound -/Last: This key is the MP3 functional complex control button, when playing music, short-time pressing can change to the last song, long-time press can reduce the volume. There are same functions when the Bluetooth is connected.</p>
	<p>Sound +/Next: This key is the MP3 functional complex control button, when playing music, short-time pressing can change to the next song, long-time press can increase the volume. There are same functions when the Bluetooth is connected.</p>
	<p>COOL DOWN (program stop function key): When the treadmill's running speed is at the time of 10km / h or more, press this button, the treadmill will automatically reduce speed to 4.6km / h to allow people to relax at low speed, after relaxing for some time ,the treadmill will stop running automatically.</p>
	<p>Start key: Press this button to start the treadmill.</p>
	<p>Stop key: Press this button to stop the treadmill.</p>
	<p>Speed reduce button: can reduce the speed.</p>

	<p>Speed increase button: can increase the speed.</p>
	<p>USB interface: You can insert the U disk with music files into this interface to play music, support MP1 Layer3, MP2 Layer3, MP3 Layer3 version of songs.</p>

Adjustment

1. Before switch on please check the voltage and earthing ok or not. Roll the running belt by hand and check whether there is noise or not.
2. Turn on the power, the monitor make a beep, windows show 0 except the heat window twinkling , running belt does not work, then press the fast/slow buttons to adjust the value of heat window to be the same with your weight. Press start button, the treadmill starts at low speed of 0.3(km /h).Observe whether the treadmill and monitor are working normally.
3. Press FAST and SLOW Key to check whether they are ok or not.
4. Press STOP key and check whether the function ok or not.
6. Put the music with MP3 format into the USB flash drive, then insert the USB flash drive to the USB socket, press the "Play/pause" key, the music will be played. And you could press "Play/pause" key again to stop it. You could choice the music with quickly clicking the "Sound-/Last" key and "Sound +/Next" key, also you could adjust the volume through press the "Sound-/Last" key and "Sound +/Next" key for a long time.

Operation guidance

1. Switch on the power

Insert three-core plug into socket (note: it must have a credible earthing); and put the safety key into the monitor ,then switch on the power, the monitor will emit a sound like beep, and all numbers in window will become to zero, then the treadmill will be in standby mode (hereinafter referred to as standby mode).

2. Start the treadmill directly

Press START key when the treadmill is in standby mode and all the numbers in the window will become to zero, and then the treadmill will work at the lowest speed; press FAST key, and then it will become faster; press SLOW key, it will become slower.

3. Setting to start

Press SET key when the treadmill is in standby mode and all the numbers in LCD window will become to zero. if you want to set any parameter, press SET key continuously, the amended number in window will begin to flash, then press FAST or SLOW key to amend this number; if press STOP key, the amended

process will be given up. Press START key after set, all amended parameter will be saved and treadmill will work as per set parameter; if the number of time and distance are set up, the number will be monished till to zero after start treadmill and then adding from zero accompanying to beep. Note: press set key continuously more than four times, the program will be changed into the menu of the pulse control speed program.

4. Pulse controls speed program

Press SET key five times when the treadmill is in standby mode and all the numbers in LCD window will become to zero, the target pulse will be shown in the window, press FAST or SLOW key to amend this number. If you press STOP key at same time, the set process will be given up; press SET key continuously, both of the speed and distance can be set up in the way above. After finish setting, grip Hand Pulse sensor and press START key, the treadmill will work at the set speed and change automatically according to the user's pulse, there by keep the user's pulse equals to the target heart rate or so. Attention: there are many factors can affect the precision of the data of heart rate and so the test data is only for reference. The maximum speed of this mode is 12km/h. It is suggested that the set speed is not more than 6km/h and the target heart rate range is 50-160 per/min.

5. Pause and stop

The treadmill will stop when you press the stop key for the first time in working mode, and all data will be kept. If you press the start key and the machine will work according to the data previously. If you press the stop key for the second time all data will become to zero.

6. Display of total distance

When the treadmill is in standby mode and all data in the window are zero, press the set key and will show set data. Press the set key again for about 3 sec and then the speed window and the distance window will amalgamate to show total distance.

7. Calculate method of calorie: People of normal weight per run 16 meters the quantity of heat that use up to 1 calories.

8. Speed direct choice

There are total 4 buttons which are located in choice speed area of monitor, the 4 buttons from 5.6.8 are easy speed choice buttons, start the machine and press any this button under easy choice of speed, the speed will be up automaticly to chosen speed.

9. Automatic speed

Treadmill in the standby state, according to the procedure set key, LCD display P01 ---- P30 heat automatically varied pace program table window. Select one paragraph, press the start button, the treadmill by pressing the corresponding program automatically adjusts the speed every 200M.

10. Manual speed

The SLOW and FAST button which is located in the lower right area are manual buttons, press SLOW or FAST button under manual choice of speed to change speed.

11. Avoirdupois set

When you switch on the power, the calorie window will be glint, and then you can choice a number same with your avoirdupois through press the key of "fast" and "slow". At last, press the "start" and the treadmill begin to run. This set could make the number displayed in the calorie window much more actual.

12. COOL DOWN (program stop function key)

When the treadmill's running speed is at the time of 10km / h or more, press this button, the treadmill will automatically reduce speed to 4.6km / h to allow people to relax at low speed, after relaxing for some time (2mins) ,the treadmill will stop running automatically.

13. Bluetooth audio instruction

After starting the machine, built-in Bluetooth began to work, the user can turn on the Bluetooth function on the phone, click on the "Search Device" will search for "HUIKANG " device name, click on the device name for the connection, if the connection is successful, the console will make a sound "beep" , light shows red, the user can open the music player software on the phone click on play, console speaker will play the music. Put the USB flash driver which have MP3 format music into USB driver, socket, the indicator shows green, left and right channel speaker can play the sounds of music. Play / Pause button can control music playback and pause, press and the next song on a music player can be selected, long press is to adjust the volume.

14. brightness adjustment

Brightness of the LCD and keypad backlight native adjustable, as follows: Press "Stop button" is at a standstill and hold for 5 seconds or more, the slope of the brightness of the display position will be the current value, press speed after subtraction buttons adjust the backlight intensity, choose your brightness value by pressing the "Start" button to save the value.

Daily maintenance

1. Running belt and running board

■ Brief instruction

Running belt is made by composite cotton-terylene fiber and special technology with a lower friction coefficient and higher tensile strength. The running board is with double shock-absorb system, the surface of running board is with high glaze and abrasion strength, it makes the sport more comfortable and smooth.

■ Cleanness

It can prolong the life of treadmill to keep it clean, so it's necessary to clean the exposed running board and side foot-board usually. Please clean running belt with soft cloths dipped water, pay attention to prevent the water into the underside of belt.

2. Lubrication

The running board/belt must be lubricated by special lubrication after a period of use, it is suggested that:

Less than 3 hours per week	half of year
3-6 hours per week	3 months
More than 6 hours per week	per month

Suitable lubrication will prolong the lifespan of the treadmill.

3. Evaluating friction

The friction between running belt and board will be increased due to the dirty or consumed lubrication, it may do harm to the motor and controller. high friction has following characters:

After switch off the power, the running belt can't be moved or it's difficult to move it by feet;

Pull out safety key when the treadmill runs at medium-speed in load mode, the running belt stops immediately.

High friction may get motor or controller damaged. For example breaker or fuse worn.

4. Belt adjustment

- 1) The running belt has already adjusted before it leaves the factory. But after a period time of using, the belt will become loose. And this is out of guarantee scope, so the user should adjust it by himself. Too loose the belt will slip, but too tight perhaps do harm to the motor and roller. Normally the distance

between the middle belt and the running board should be kept 5-6cm. How to evaluate the loose running belt: Operate the treadmill at a speed of 1.5km/h, hold the handrail tightly and stop the running belt by user's feet, if the running belt stops moving but the front roller still moving and it will move again after letdown, this means the running belt is too loose so the user will have a feel of pause. In this case, the using life of the motor belt will be shortened, so the user should adjust it in time.

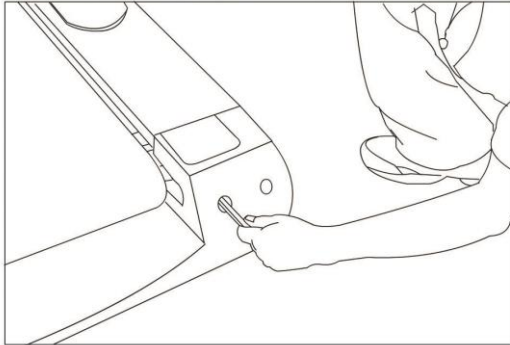

2) Loose belt adjustment

After use for a period of time, the user could feel a pause during running; it is due to the loose belt. The method to solve this problem is to tighten adjustable bolt which is respective in the left and right end of treadmill till you have no pause feeling.

Friendly indication: it's not more tight, more better for the belt. The running belt should be adjusted according to your need. Too tight running belt will shorten the life span of running belt.

5. Deflection belt adjustment

All the running belts have already adjusted before the treadmill leaves the factory and after assembling, but after a period time of using, the belt may become deflected. It usually caused by the following reasons:

- 1) The body of treadmill is not placed well.
- 2) The user's feet are not on the center of the running belt.
- 3) The strengths of user's two feet are different.
- 4) For the deflection made by human the machine will adjust by working several minutes without load. For other reasons please adjust the bolt at a unit of half-circle by the accompanying tool. If the belt slants to left, please adjust the left bolt in clockwise direction or adjust the right bolt in counter clockwise direction; if the belt slants to right, please adjust it contrary direction. The deflected running belt is out of guarantee; the user should adjust it by himself. The deflected running belt will strictly harm itself, so the user must adjust it in time.

6. Motor belt adjustment

- 1) All motor belts have been adjusted well before the treadmill leaves the factory. But after use for a period of time it may get paused in short time. Maybe the motor belt is too loose.

- 2) How to evaluate the motor belt loose or not

Get the treadmill work at a speed of 1.5km/h, hold the handrails tightly and try to stop the running belt contrary direction by user's feet, if the running belt and front roller stop simultaneously but moving again after letdown, it means the motor belt is too loose and the user may have a pause feeling. You should adjust it immediately because this may do damage to the lifespan of motor belt.

- 3) solution: adjust the motor bolt in clockwise direction at unit of half-circle by accompanying tool till the user have no feeling of pause.

Special attention: It's not more tighter, more better for the driving belt. Too tight or loose of the belt will shorten the life span of the driving belt.

Common failure and maintenance

1. Malfunction of display

- 1) After switch on the power, the digital transistor doesn't display and the buzzer keeps ringing. Solution: change the monitor.
- 2) After switch on the power, the machine can be started and all displays are normal, but both the FAST and SLOW key doesn't work. Solution: change the monitor.
- 3) After switch on the power, each digital transistor displays the same strokes, the buzzer has no sound and all the keys don't work. Solution: change the monitor.
- 4) After switch on the power and do not to press start key, the treadmill starts at a lower speed, and the FAST key and SLOW key don't work. Solution: change the monitor.
- 5) The START and STOP key work normally, the speed can become fast but can't become slow, the keys were damaged or the signal cable is not in good connection. Solution: change the monitor.
- 6) The digital transistor can't display or only display half-baked number, the digital transistor was damaged but treadmill can work normally. Solution: change the monitor.
- 7) Press start key, the treadmill works at an initial speed, but stop after 5 seconds. Solution: change the monitor.
- 8) After start treadmill, it only displays unchanged speed in the speed window; and FAST and SLOW key can't change the speed. Solution: change the monitor.
- 9) After switch on the power, the digital transistor flashes regularly. Method: make sure the safety key on the right position. If the digital transistor still flashes regularly, please change the monitor.
- 10) Without the safety key and switch on the power, the digital transistor doesn't flash, press START key, the treadmill works normally. Solution: change the monitor.

2. Malfunction of Controller

- 1) After switch on the power and press START key, the treadmill works at a high speed and can't stop
- 2) After switch on the power, the display and the buzzer work; press START key, the time in the window can be record 5 seconds and then the buzzer rings again, but the treadmill can't work.
- 3) The display of the monitor and the buzzer is normal, but the running belt doesn't move after startup.
- 4) After switch on the power, the monitor displays normally; the relay can't close after setup and the belt moves a little distance then stop soon.
- 5) After switch on the power, the monitor displays normally, the relay can't close and press START key, the treadmill doesn't work.
- 6) After switch on the power, the fuse is broken down.

Solution: for the 6 malfunctions above please replace the controller.

3. Malfunction of the motor

- 1) After startup, there's collision sound or biggest noises from the motor.
Reason: the motor was damaged.
Solution: maintain or replace the motor.
- 2) After switch on the power, the leakage protector opens circuit and the motor is creep age.
Solution: replace the motor.

Foldable operation

Folding the upper cylinder light kick with their feet, gently down the host. Folding treadmill should ensure that the cylinder lock and then move the treadmill or leave.

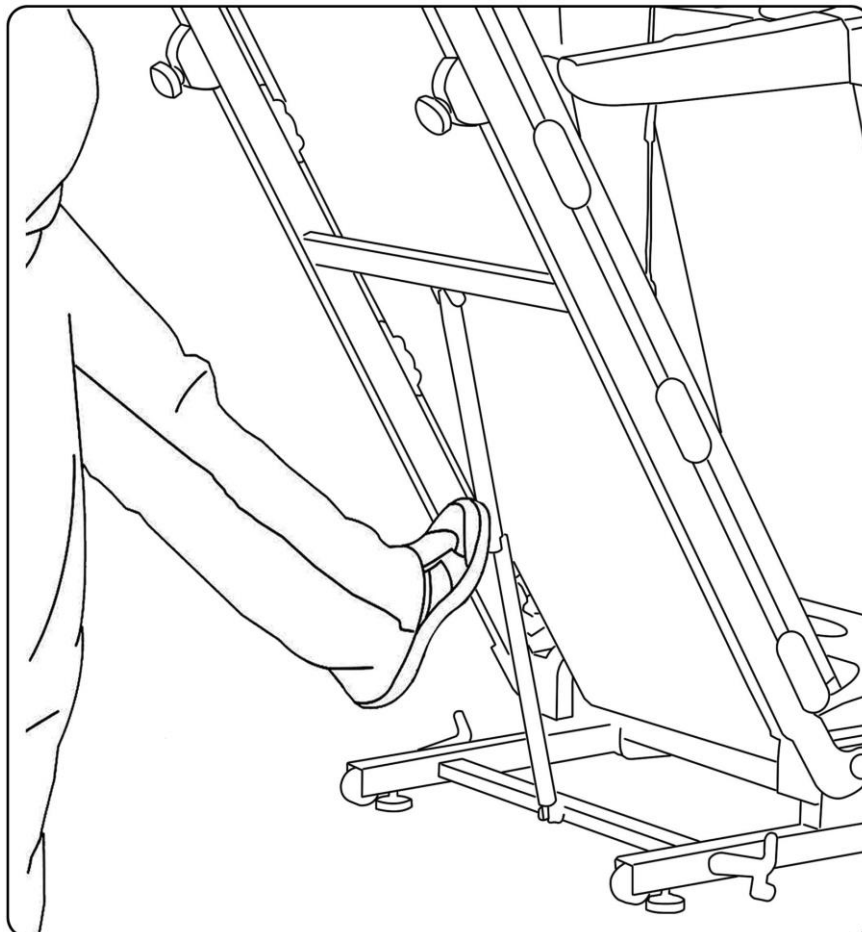

chart of safety area

