

3. WARNING:

WARNING

To reduce the risk of injury, adult supervision is required. Strictly forbidden using on the roadways, near motor vehicles, slopes, swimming pools and where there is water; Please wear shoes; this toy car can only be used simultaneously by one person. Keep away from kids before assembled by adult, as there are potentially sharp edges, points, or small parts.

WARNING

Do not mix alkaline battery, standard (carbon-zinc) battery or rechargeable (nickel-cadmium) battery.

WARNING

Protective equipment should be worn. Not to be used in traffic.

WARNING

This product is unsuitable for children under 3 years due to its maximum speed.

Repair and Maintenance

- 1) The product contains electronic components and must not be used in water or in a damp environment. Clean it with a piece of wet cloth.
- 2) Rotating parts should be checked regularly, to see whether they are jammed by any sundries and to keep their normal lubricating state.

K07-SMS-150-002

002-01

Installation and Operating Instructions

BMW M6 GT3 Battery Operated Ride On



Please read the operating instructions carefully before use

The BMW logo and the BMW wordmark are trademarks of BMW AG and are used under license. They are used by Dongguan Chi Lok Bo Toys Company Limited under license.

Dimensions of entire car

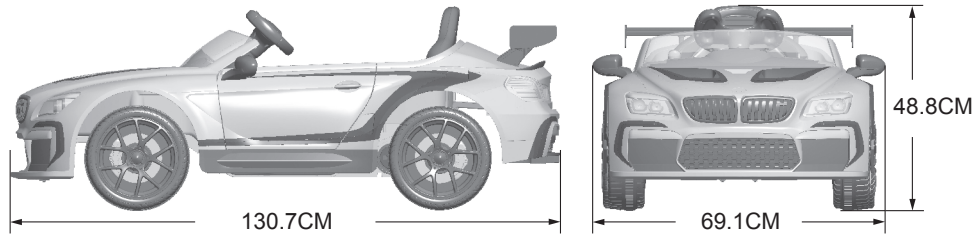

Contents

- I. Product specifications and parameters
- II. Components List
- III. Assembly Diagram
- IV. Installation and replacement of remote control batteries
- V. Function and Operation
- VI. Battery and Charger Operating Guide
- VII. Simple Fault Removal Guidance
- VIII. Warning

Model:	Option A	
Battery specifications:	DC 12V / 7 AH	
Product charger:	DC 15V / 800 mA	
Product driving motor:	DC 6V / 12000r (550 dual drive)	
Product speed:	2.5 / 3.4 / 4.2 km / h	
Over-current protection:	6A	
Remote control:	Yes	
Remote control DC power supply:	2 × 1.5V AAA	

Model:	Option B	
Battery specifications:	DC 6V / 7 AH	
Product charger:	DC 8V / 750 mA	
Product driving motor:	DC 6V / 12000r (550 single driving)	
Product speed:	2.4 / 3.1 / 3.8 km / h	
Over-current protection:	8A	
Remote control:	Yes	
Remote control DC power supply:	2 × 1.5V AAA	

Model:	Option C	
Battery specifications:	DC 6V / 7 AH	
Product charger:	DC 8V / 750 mA	
Product driving motor:	DC 6V / 12000r (550 single driving)	
Product speed:	2.4 / 3.1 / 3.8 km / h	
Over-current protection:	8A	
Remote control:	No	
Remote control DC power supply:	No	

I. Product specifications and parameters

1. This product is suitable for the children of 3-6 years old, and should be used under adult supervision!
2. Product dimensions: 130.7 × 69.1 × 48.8CM
3. Product maximum load weight: 30 kg
4. Product charger: input AC 100-240V (50 / 60Hz), Output (See charger parameters of the product)
5. Charging battery: (See the optional parameters) (1 battery) it can provide about 200 cycles of charging and discharging
6. (Option A, Option B) Remote control and manual switching functions, 2.4G one-to-one remote control function
7. DC power supply of the remote controller: (See the optional parameters) (The battery of this product is not included)
8. Product operating ambient temperature: 0-40℃

VIII. WARNING

1. Battery warning:

- 1) If the product is not used for a long time, please fully charge the battery and then turn off the power switch for storing the car. The battery shall be recharged once every other month, otherwise the battery service life will be shortened or the battery cannot be charged again.
- 2) Pay attention to the positive and negative poles of the battery during installation (the reverse connection or short circuit of the positive and negative poles of the battery is not allowed to occur).

Battery warning:

- 1) This product needs to be provided with two DC 1.5V AAA batteries (not included in this product).
- 2) Pay attention to the positive and negative poles of the battery during installation (the reverse connection or short circuit of the positive and negative poles of the battery is not allowed to occur).
- 3) Rechargeable batteries charging operation can be carried out only by adults.
- 4) Non-rechargeable batteries cannot be charged.
- 5) The rechargeable batteries can be charged only after being taken out from the remote control battery compartment.
- 6) Please do not mix different types of batteries or used batteries and new batteries.
- 7) If this product has not been used for a long time, the batteries shall be taken out from the remote control battery compartment.
- 8) Exhausted batteries are to be removed from the toy.

2. Product warning:

- 1) There may be potential sharp edges, sharp points or small parts before the assembly of this product, and therefore this product shall be assembled by the adult.
- 2) To avoid suffocation, keep the plastic bag away from children. Dispose of all bags immediately.
- 3) The children shall correctly use the car under the adult guidance and supervision, otherwise they may make themselves or the others injured.
- 4) The car is suitable for being driven on the flat ground and strictly prohibited to be driven in such dangerous places as street, road, steep slope and beside swimming pool, otherwise the traffic and drowning accidents may occur.
- 5) Please put on shoes and protection equipment before use, such as fastening the safety belt and putting on the helmet, gloves, knee pads, etc.
- 6) Small parts possibly fall off when this product is used improperly. So, it is unsuitable for children under 36 months old.
- 7) Regularly check whether the battery, charger, wire, plug, casing and other parts are damaged; if the damage occurs, please cease to use this product until it has been repaired.
- 8) This product is only allowed to be used by a child; the maximum load is 30kg, and therefore the overload is not allowed.
- 9) Keep away from fire.
- 10) The product instructions shall be kept as they contain important information.

VII. Simple Fault Removal Guidance

Defective conditions	Key points of inspection
1. The car cannot be started.	1) (Option A) Check if the battery is fully charged, and you can observe the display of the central control panel to check whether the voltage is above 12V. (Option B, Option C) Check if the battery is fully charged, and you can observe the display panel of the central control panel to check the voltage is above 6V.
	2) Check the power switch, all plugs of the dash receiver under the seat, and the battery terminal line are properly inserted.
	3) Check whether the circuit of the over-current protector is automatically disconnected (When the motorcycle is overloaded and blocked, the circuit of the over-current protector will be disconnected to protect the motor, dash receiver and control panel.)
	4) Whether the car is stored for a long time without application and the battery is not charged on schedule.
	5) If the remote control cannot start the car, please check whether the remote control code-matching function is normally operated.
	6) Check whether the remote control battery power is low.
2. Music sound is distorted or silent	Check whether the battery power is enough, and charge or replace the battery if not.

Operation of overcurrent protector

- The overcurrent protector is installed under the seat. You can see it by twisting the seat screw off (As shown in the figure) and taking the seat away.
- When the car is overloaded, the overcurrent protector automatically disconnects the circuit (For protecting the circuit); when the circuit fault is removed, the overcurrent protector automatically connects the circuit.
- When the battery has power and the car can not run, please check whether the circuit of the car has an open circuit or short circuit.

(Option A)

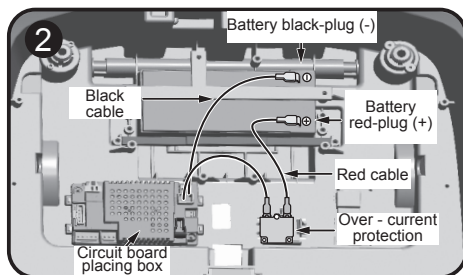
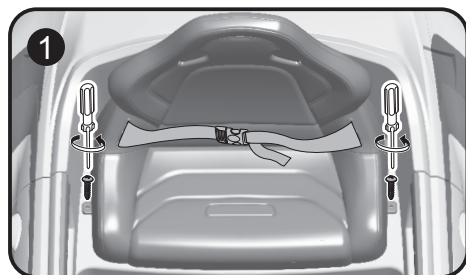

Warning Fire danger! The overcurrent protection is only limited to 6A.

(Option B)

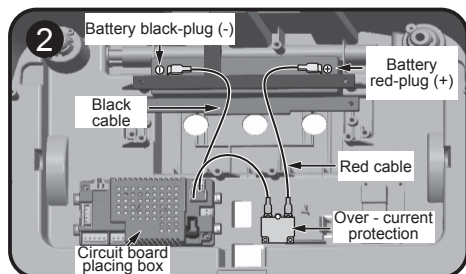





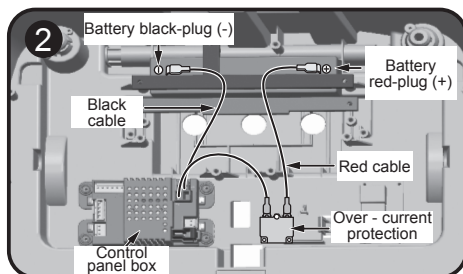





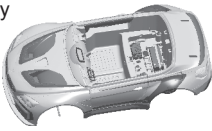
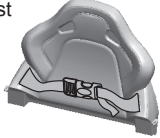







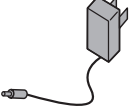

Warning Fire danger! The overcurrent protection is only limited to 8A.

(Option C)



Warning Fire danger! The overcurrent protection is only limited to 8A.

II. Components List

1. Car body 	9. Seat backrest 	17. Steering gearbox screw (3 × 10PWAB) (D=10) 2PCS 
2. Windshield 	10. Tail wing 	18. Rear-view mirror screw (3 × 12PAB) 4PCS 
3. Steering Wheel 	11. Front axle frame connecting-rod 	19. Front axle frame connecting rod locknut (5MM) 2PCS 
4. Rear-view mirror 	12. J-shaped stick 	20. Steering wheel locknut (5MM) 
5. Hand shank 	13. Rear wheel axle 	21. Charger 
6. Wheel (Option A 2PCS) (Option B, C 3PCS) 	14. Front axle frame connecting-rod screw (5 × 13PM) 2PCS 	22. Remote Control (Option A, Optional B) 
7. Driving wheel (with rubber wheel sleeve) (Option A 2PCS) (Option B, C 1PC) 	15. Steering wheel screw (5 × 33PM) 	23. Plastic tube (Option B, Optional C) 
8. Seat 	16. Seat and backrest screw (4 × 15TAB) (D=7.5) 4PCS 	

III. Assembly Diagram

1. Installation of front axle frame connecting-rod and wheel (Optional A)

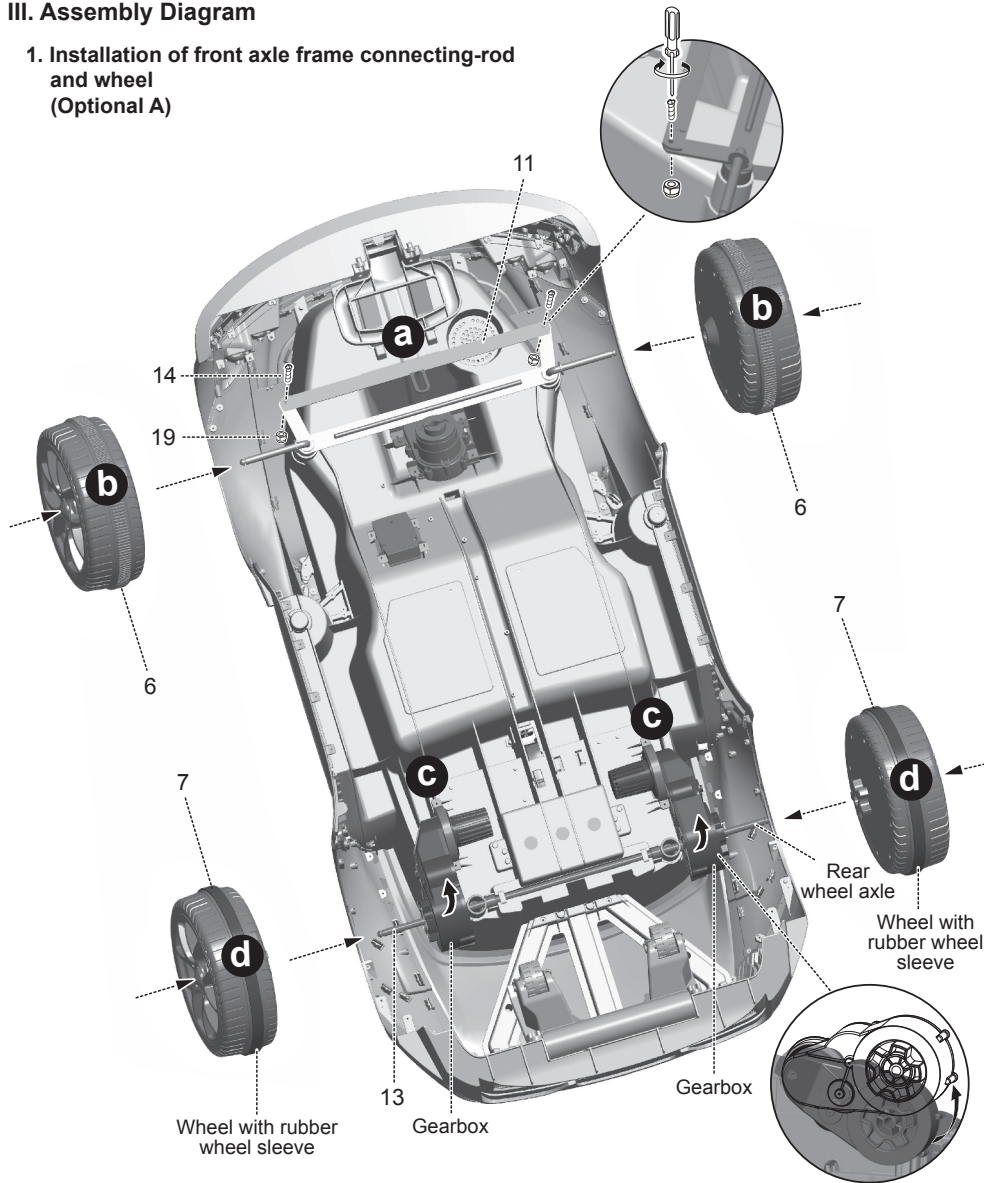

Remarks: Optional C don't have steering gearbox

- a** Install the front axle frame connecting-rod (part 11) at the assigned location, and then tighten it with the front axle frame connecting-rod screw (part 14) and locknut (part 19). (The tightening degree shall be based on the flexible swing direction.)
- b** Use the thumb to press the wheels (part 6) center button, and then put them into the front axle in sequence.
- c** Rotate the motor gearbox upwards according to the direction indicated by the arrow until the motor gearbox hole aligns with the car body axle hole, and then insert the rear axle (part 13) into the assigned location of the car body.
- d** Use the thumb to press the center button of the driving wheels (part 7) to put them into the rear wheel axle in sequence.

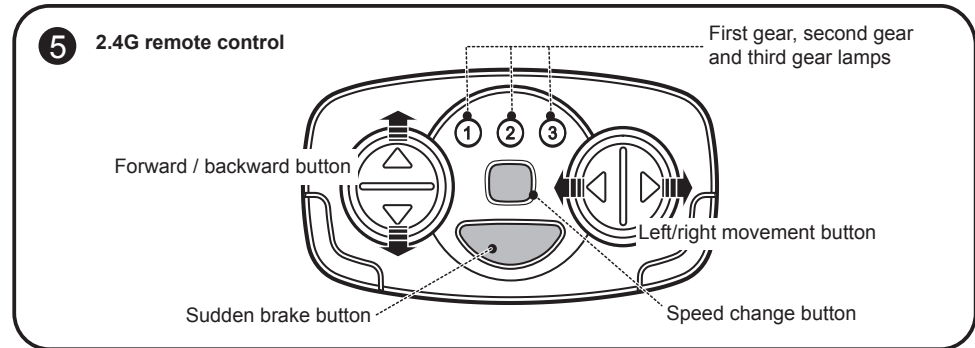
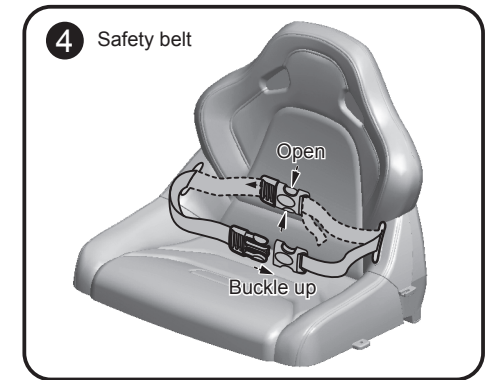
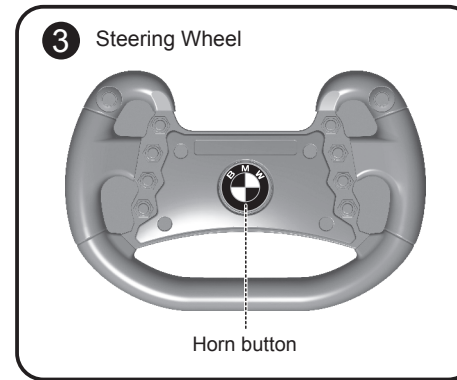

VI. Battery and Charger Operating Guide

1. The charging socket is located at the lower part of the car seat.
2. The battery and charger which are provided or recommended by Chilokbo can be used only.
3. Please do not play with the charger and battery because they are not toys.
4. The battery charging operation is carried out only by adults but not children.
5. The color of the charging status lamp in the charger is red during charging and turns green after being fully charged.
6. The battery should be fully charged before first use, cannot exceed 15 hours.
7. (Option A) When the display voltage is as low as 9.6V, please charge it immediately.
(Option B, Option C) When the display voltage is as low as 4.8V, please charge it immediately.
8. The lukewarm phenomenon of the charger and battery will occur during charging.

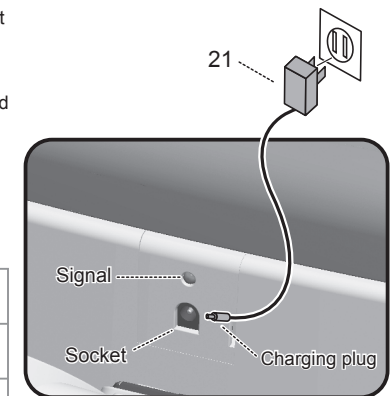

Power Supply	Chargeable type	
Battery specifications	(See the option parameters)	
Over-current protection	(See the option parameters)	
Product charger	Input AC 100V-240V 50Hz / 60Hz	Output (See charger parameters of the product)
Battery Charging Time	Charging Time: 9-10 hours	Utility time: 1-2 hours

3. Normal operation:

1) Foot switch mode

- A. Press the main power switch button B. Press the foot pedal button (Option A, Option B) C. Select the forward / reverse direction D. Select the speed gear E. Step on the pedal to start

2) Remote control code-matching operation (Option A, Option B):

- A. Press the main power switch button to turn it on (Coding will be valid within two minutes after powering on)
 B. Simultaneously keep pressing the speed change button and sudden brake button of the remote control for 5 seconds; if the lamp of first gear, second gear and third gear twinkles, it will indicate that the code-matching action is transmitted; it will indicate that the codes are matched successfully until the lamp is on and stops twinkling; when the code-matching action is received, the front wheel will rotate leftwards for 1s and rightwards for 1s.

3) Remote control function (Option A, Option B):

- A. Forward / Backward button B. Left/right movement button C. Sudden brake button D. Speed change button
 E. It will enter the sleep state if no operation occurs within 1 min. You can press any button to reawaken it.

(Option A)



(Option B, Option C)

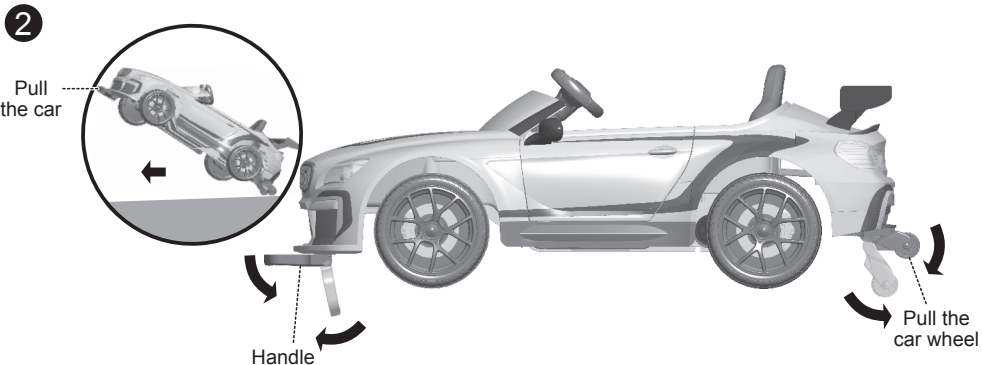

(Option B, Option C) Installation of rear wheel

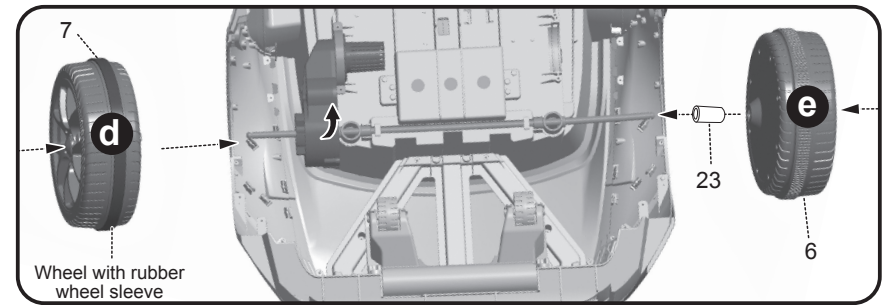

e Insert the rear wheel cartridge (part 23) into the rear axle in sequence, and press the center button of the wheel (part 6) with your thumb to fit the rear axle.

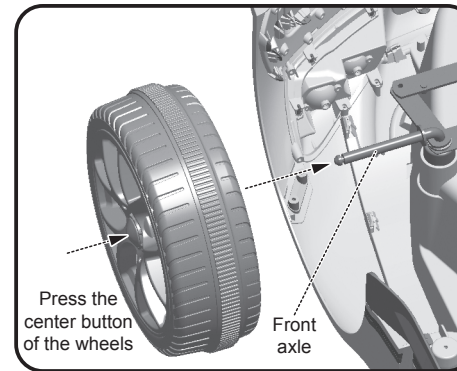

When the wheels are installed, press the center button of the wheels, insert the wheels into the front axle and fix them; press the center button of the wheels to pull out the wheels from the axle so as to remove the wheels.

2. Installation of J-shaped stick

(Option A, Option B)

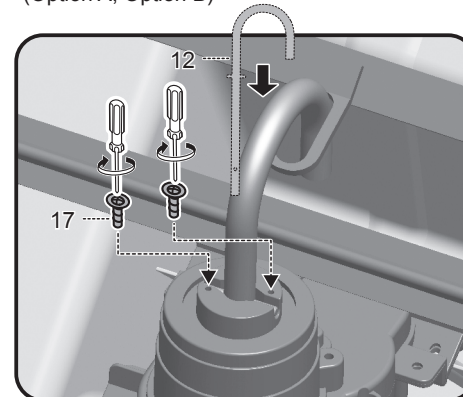

Insert the J-shaped iron hook (part 12) into the designated gearbox at the front of the car. Then tighten with the hole specified by the steering gear box screw (part 17).

(Option C)

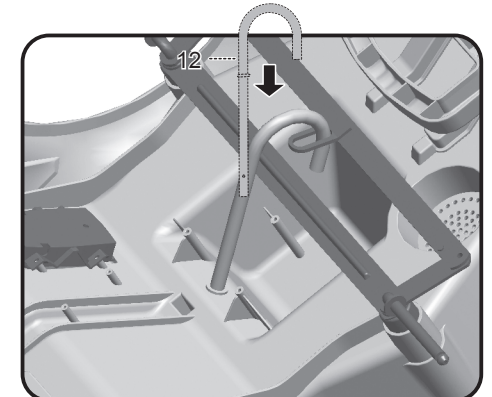

Insert the J-shaped iron hook (part 12) into the designated position in front of the car.

3. Install the rear-view mirror

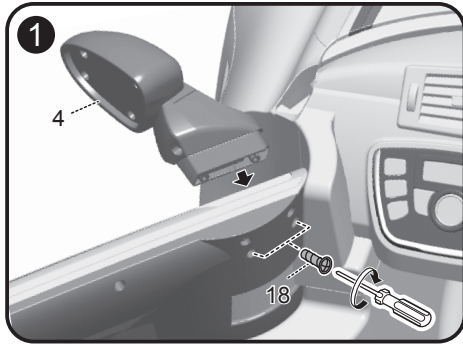

Open the door, install the inverted mirror (part 4) in the specified position, and tighten the inverted mirror with screws (part 18) as shown.

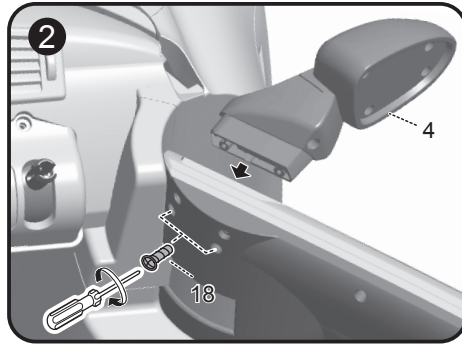

4. Installation of steering wheel and hand shank

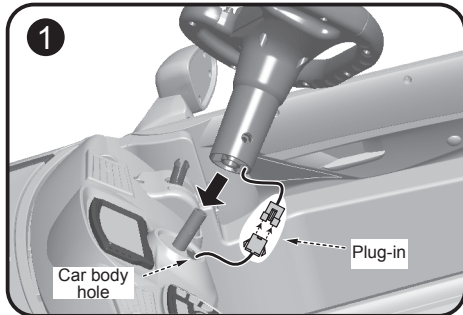

Plug the wire plug of the steering wheel into the wire plug from the car body hole correspondingly, and then put the connected plugs into the car body hole.

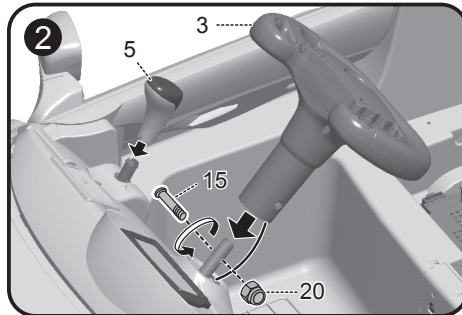

Install the steering wheel (part 3) on the J-shaped iron hook, and tighten with the steering wheel screw (part 15) and the steering wheel anti-loose nut (part 20); then insert the handle (part 5) into the designated position and press down firmly to make it reliably connected.

5. Installation of power supply

(Option A)

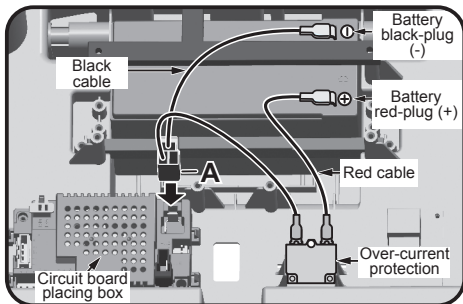

Insert plug (A) into the circuit board to its bottom.

(Option B)

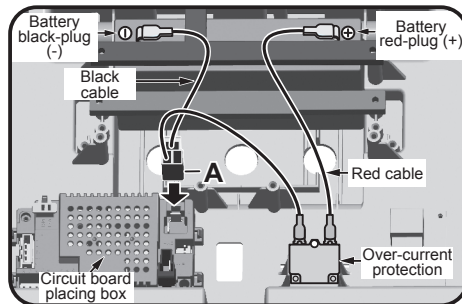

Insert plug (A) into the circuit board to its bottom.

11) Mode switch button:

(Option A)	<ol style="list-style-type: none"> It is by default the built-in music play mode, and there is "music player" English prompt sound, and the display "MUSIC" will be always on; Press this button and switch to USB mode, and there is "USB mode" English prompt, and "USB" on display will flash (Flash when USB is not connected, and it will be always on when it is connected to USB); Press this button again and switch to BT Bluetooth mode, and there is "bluetooth mode" English prompt, "BT" on display will flash (Flash when Bluetooth is not connected, and it will be always on when Bluetooth is connected); Press this button again and switch back to the built-in music playback mode. <p>(It will be as such) → Press → USB mode → Press → BT mode → Press → Music mode Loop</p>
(Option B, Option C)	<ol style="list-style-type: none"> It is by default the built-in music play mode, and there is "music player" English prompt sound, and the display "MUSIC" will be always on; Press this button and change to MP3 mode, and there will be "MP3 mode" English prompt voice, and "MP3" will flash on the display (It will flash when MP3 line is not inserted and it will always be on when the MP3 line is inserted); Press this button again to change back to the built-in music playing mode.

12) Display function:

(Option A)	<p>Four digits display: ① The middle four digits display the voltage of the battery in real time; it will display the volume change in adjusting the volume (U00-U30); which song (0001-9999) in USB music will be displayed during USB playback.</p> <p>② The function icons on both sides of the display are "MUSIC, USB, BT, V, ►, ■", and the mode or state in which it lies will be displayed by its corresponding icon.</p>
(Option B, Option C)	<p>Four digits display: ① The middle four digits display the voltage of the battery in real time; it will display the volume change in adjusting the volume (U00-U30)</p> <p>② The function icons on both sides of the display are "MUSIC, MP3, V, ►, ■", and the mode or state in which it lies will be displayed by its corresponding icon.</p>

- 13) (Option A) Bluetooth playback function: ① In Bluetooth mode, after connecting Bluetooth, the "BT" on display will be always on, and then the audio file in the Bluetooth device can be played.
 ② When Bluetooth is disconnected, there is a "dingding" prompt tone, and "BT" on display will flash.
 ③ Name of Bluetooth: CHILOKBO

- 14)  (Option A) USB playback function: In USB mode, after connecting USB, the "USB" on the display will be always on, and then the audio file in USB can be played.

- 15)  (Option B, Option C) MP3 playback function: In MP3 mode, after plugging the MP3 line, the "MP3" in display will be always on, then the external sound file can be played.

- 16) Steering wheel button: The middle is the horn sound button, which will be sounded in any audio playback mode; press and hold this button, the horn will sound continuously.

- 17) Sleep function: The system will enter sleep mode when it is without driving for 30 min, and the central control board will automatically shut down, and all functions will turn off!

18) Low voltage protection function:

(Option A)	When the voltage is as low as 8V, the central control board will automatically power off and the car will stop automatically. Please charge as soon as possible!
(Option B, Option C)	When the voltage is as low as 4.5V, the central control board will automatically power off and the car will stop automatically. Please charge as soon as possible!

- 19) Charging and power-off function: When charging the car, the central control board will automatically power off. All functions will be turned off, and the car cannot be started!

2)  Music button: Under MUSIC play mode, press this button to play a song, and the green light of this button is on; press this button again to play the next song; there are 2 music buttons, each button will play 3 songs repeatedly.

3)  Previous\Volume - Button:

(Option A)	<p>① In MUSIC USB BT mode: short press this button, the green light of this button will be on for a short period of time and it will change to the previous music; long press this button for 2 seconds without releasing, the green light of this button will be on, the volume will be decremented, the volume value on display will decrease from U30 to U00.</p> <p>② Each time of starting, the default volume value will be U25.</p>
(Option B, Option C)	<p>① In MUSIC playback mode: short press this button, the green light of this button will be on for a short period of time and it will change to the previous music;</p> <p>② In MUSIC and MP3 playback mode: long press this button for 2 seconds without releasing, the green light of this button will be on, the volume will be decremented, and the volume value on the display will be decremented from U30 to U00.</p> <p>③ Each time of starting, the default volume value will be U25.</p>

4)  Next music \ Volume+ button:

(Option A)	<p>① In MUSIC USB BT mode: short press this button, the green light of this button will be on for a short period of time and it will change to the next music; long press this button for 2 seconds without releasing, the green light of this button will be on; the volume will increase and the volume value on the display will be displayed incrementally from U00 to U30.</p> <p>② Each time of starting, the default volume value will be U25.</p>
(Option B, Option C)	<p>① MUSIC playback mode: short press this button, the green light of this button will be on and it will change to the next music;</p> <p>② In MUSIC and MP3 playback mode: long press this button for 2 seconds without releasing, the green light of this button will be on; the volume will increase, and the volume value on display will be displayed incrementally from U00 to U30.</p> <p>③ Each time of starting, the default volume value will be U25.</p>

5)  Light / fan button:

(Option A)	<p>The start button is in "off" mode by default, press once to turn on the light, and the green light will be on; press again to turn on the fan, and the light will be off; press the button for the third time to turn on both the light and fan; press the button for the fourth time to turn off both the light and fan, and at the same time, the green light of this button will be off.</p> <p>(It will be as such → Press → Turn on the light → Press → Turn on the fan (Turn off the light) → Press → Turn on both the light and the fan → Press → Turn off both the light and the fan → Loop)</p>
------------	---

6)  Light button:

(Option B, Option C)	It is by default in off status; press it once, the light will turn on, and the green light will be on; press it again, the light will turn off, and the green light will turn off.
----------------------	--

7)  (Option A, Option B) Foot switch button: ① It is by default in the foot switch mode, and the green light of this button will be on; then turn on the gear, and step on the foot switch to start and loose the foot switch to slow down the car; press the remote control button to stop the car forcefully. (The car can't be started by foot switch when it is stopped by the remote controller!) ② Safety protection function: Before starting the car by stepping on the accelerator or switching from the remote control mode to the footswitch mode, you must first loosen the accelerator pedal and then step on it.

8)  (Option A, Option B) Remote control button: When this button is pressed, the system will switch to the remote control mode, and the green light will be on, then the remote controller can be used to drive the car. (At this time, stepping on the accelerator pedal is unavailable!)

9)  (Option C) Cheering button: Press this button once to send a cheering sound. The green light of this button will be on and it will be off when the sound stops.

10)  (Option C) Brake sound button: Press this button once to send a brake sound. The green light of this button will be on and it will be off when the sound stops.

(Option C)

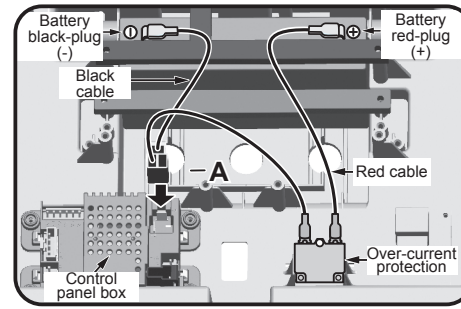

Insert plug (A) into the circuit board to its bottom.

6. Install the seat and seat back

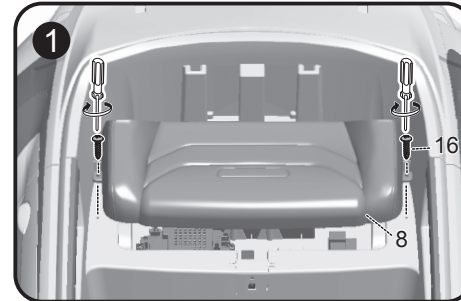

After the power supply is installation, put the seat (part 8) into the assigned location of the car body, and fix it with the screw (part 16).

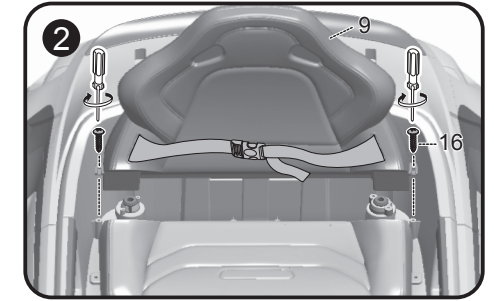

Put the seat backrest (part 9) into the assigned location of the car body as shown in the figure below, and tighten it with the seat backrest screw (part 16).

7. Install the windshield and the empennage

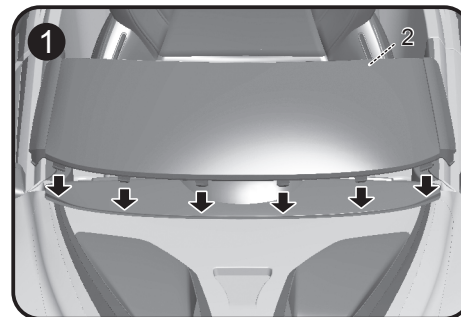

Install the windshield (part 2) at the specified position on the front of the car. Before the installation, fix the position of each buckle and press until it is firmly fastened.

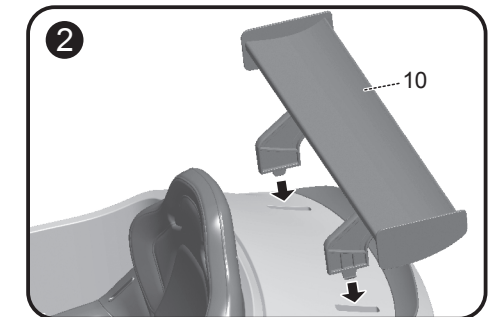

Insert the rear wing (part 10) at the direction shown by the arrow, and insert the corresponding buckle, and press the buckle firmly until it is fasten.

8. Open the car door

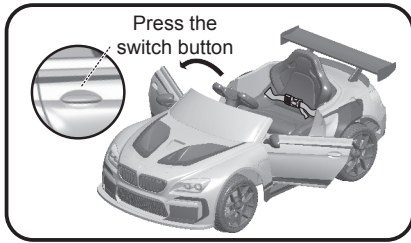

Press on-off button outside the vehicle door sheet, then pull the vehicle door outside and open the door.

IV. Installation and replacement of remote control batteries (Option A, Option B)

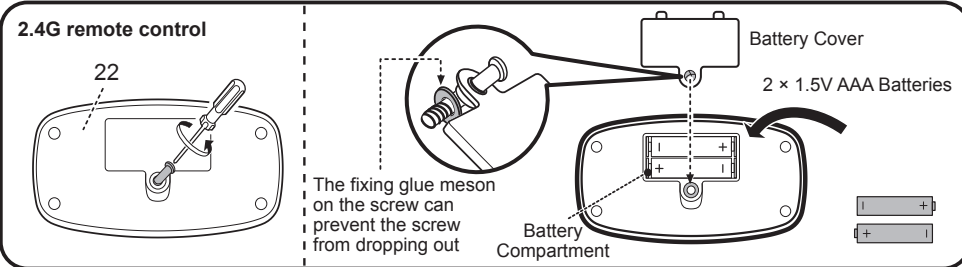

Unscrew the battery cover screws of the remote control (part 22), open the battery cover, find the positive and negative poles, put 2 AAA batteries into the battery compartment, close the battery cover and fix it with screws.

V. Function and Operation

1. Main functions:

- 1) There are remote controllable and pedal switch buttons. (Option A, Option B)
- 2) Rear drive: Power motor gearbox provides powerful "front or rear" power.
- 3) Forward / backward function: There are three forward speed level, neutral gear and reverse gear on right side of the panel (each gear has its own LED display)
- 4) Foot switch function: Press the foot switch button, when the handle is in forward or backward position, step down the foot switch to move the car forward or backward, and release the foot switch to stop the car.
- 5) Charging protection function: All functions needing to be powered by the battery will fail when the battery is being charged.
- 6) Forward / backward brake function: It has relay brake function whether it is moving forward or moving backward or parking.
- 7) Turn the auxiliary pull wheel at the bottom of the car out, and turn the pull handle at the front bottom of the car out to pull it away.

2. Functions on the central control board:

(Option A)

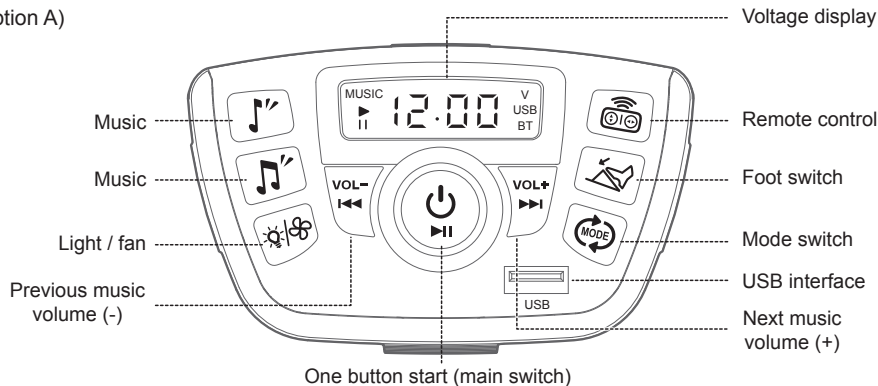

(Option B)

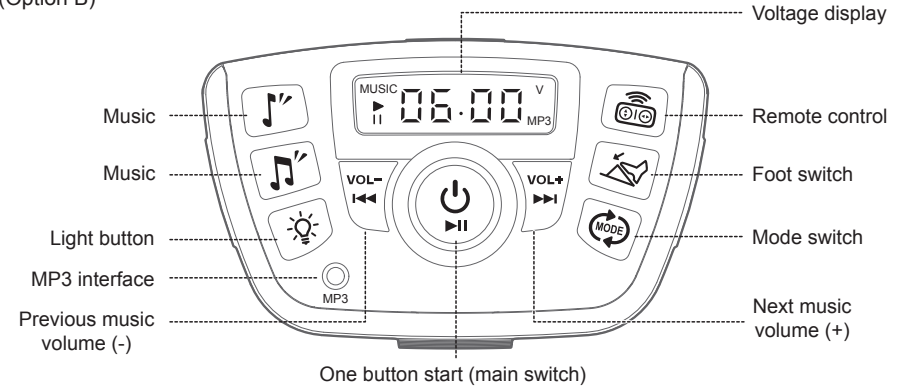

(Option C)

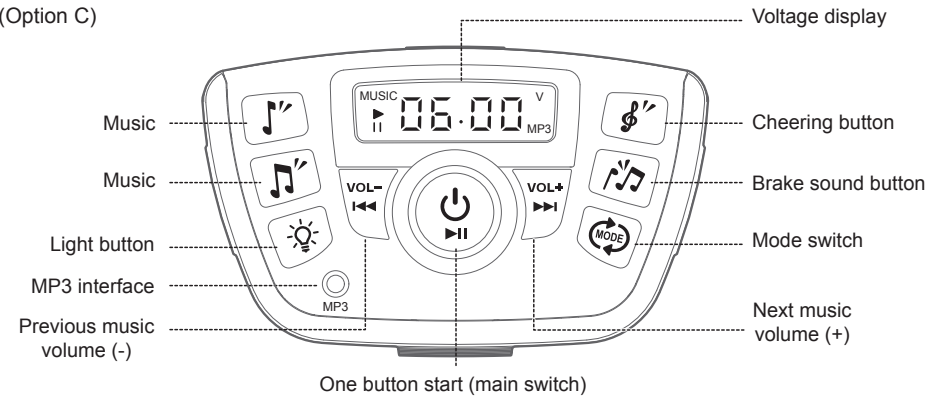

- 1)  One-button start button:

(Option A, Option B)	<ol style="list-style-type: none"> ① Press this button to turn on the main power, and the system is in standby mode, and the trumpet gives a sound of engine. Red light of one button start button and green light of foot switch mode button will be on, displaying "00.00" with "V", and the normal voltage will be displayed after the engine sound; then the English prompt sound of "music player" music is played, and the music button will be invalid until the prompt sound is over. ② After pressing this button for 2 seconds, the main power will be cut off and the system will be shut down.
(Option C)	<ol style="list-style-type: none"> ① Press this button once to turn on the main power switch, the system will be in the standby state, and the speaker will emit a car engine sound, and the red light of the one-button starting button will be on; the display will show "00.00" and "V", and the normal voltage will be displayed after the engine sound ends. Next, the English prompt with "music player" music will be played, and the music button will be invalid before the prompt sound is over. ② After pressing this button for 2 seconds, the main power will be cut off and the system will be shut down.