

Please keep this manual properly.

NOTE

1. All photos in this manual are used to specify the operation and construction of the product. When you find some differences between the product and the photo, please follow the product.
2. We won't notify you when we modify the construction and appearance of the product partially in order to improve the product quality.

Children Car

OPERATION MANUAL

MINI-SCOOTER SERIES



Please read this manual carefully before operation.
The children must operate the vehicle under operation instruction.
The vehicle complies with standards:
 GB6675-2003,GB19865-2005,GB5296.5-2006;
 ASTM F963;
 EN71,EN62115.

Specification

Item No.	LS-128A
Age properly	36-96 months old
Vehicle Size	820x420x560MM
Net Weight	5.25KGS
Load Capacity	25KGS
Environment Temperature	0-40°C
Speed	Approx. 2.5km/h
Battery	6V4.5AHx1
Charger	Input AC220V-240V/50Hz-60Hz, or AC110V-120V/50Hz-60Hz,Output DC6V500MA
Motor	6V 12W
Charging Lifetime	Approx. 300 times
Operating Time	Operating 40 minutes when charging 8-10 hours once
Charging Time	Less than 10 hours once

 **NOTE:**The manual contains many “Warnings” and “Cautions” concerning the consequences of failing to maintain,inspect or properly use your toy because any incident can result in serious injury or even death,we do not repeat the warning of possible serious injury or death each time such a warning is mentioned.

AN IMPORTANT MESSAGE TO RIDERS AND PARENTS: READ THIS ENTIRE MANUAL BEFORE OPERATING OR ALLOWING USE OF THE TOY,AND KEEP THIS MANUAL AVAILABLE FOR FUTURE REFERENCE. This manual contains important information.For safety reason,it is your responsibility to review this information and make sure that all warnings ,cautions,instructions,and safety topics and assure that young riders are capable and able to use this product safely and responsibly. We recommend that you periodically review and reinforce the information in this manual with younger riders ,and you are required to inspect and maintain your child's vehicle to insure their safety. The recommended rider age is only an estimate and can always being affected based upon a particular rider's size,weight or skills.If the rider is unable to fit comfortably on the toy,don't attempt to ride on it.



GENERAL WARNING: Riding on the toy can be a hazardous activity. Electric vehicles can, and are intended to, move and it is therefore possible to get into dangerous situation and/or lose control and/or fall off. If such things occur you can be seriously injured or die. **LIKE ANY OTHER MOVING PRODUCT, USING THE TOY CAN BE A DANGEROUS ACTIVITY AND MAY RESULT IN INJURY OR DEATH EVEN WHEN USED WITH SAFETY EQUIPMENT AND OTHER PRECAUTIONS.USE AT YOUR OWN RISK AND USE COMMON SENSE.**

- Always check and obey local laws or regulation which may affect the locations where the toy may be used on . The toy is meant to be used only in controlled environments free of potential traffic hazards, and not on public streets or sidewalks. Do not try to ride your toy on public streets or in any area where pedestrian or vehicle traffic may present a risk of collision or injury to yourself or others. Watch out for potential obstacles including pedestrians, skaters, skateboards, bikes, children or animals who may enter your path, and respect the rights and property of others.
- Do not ride the toy in wet weather and never immerse the toy in water, as the electrical and drive components of the toy could be damaged by water or create other possibly unsafe conditions.
- The toy is designed to perform best outdoors on solid, flat, clean and dry surfaces. Wet, slick or uneven and rough surfaces may impair traction and contribute to possible accidents. Use only on flat, dry, level ground without loose debris, such as rocks or gravel. Do not ride a toy in mud, ice, puddles or water. Avoid excessive speeds that can be associated with downhill rides.Never risk damaging indoor surfaces such as carpet or flooring by use of a toy indoors.
- Do not ride at night or impaired visibility conditions.
- Always wear proper protective equipment, such as an approved safety helmet, elbow pads and kneepads. A helmet may be legally required by local law or regulation in your area, and should always be worn when riding it. Always wear shoes, never ride barefooted or in sandals, and keep shoelaces tied and out of the way of the wheels, motor and drive system.
- Do not exceed the weight limit of 25 KGS.
- Do not attempt or do stunts or tricks on your toy. The toy is not made to withstand abuse from misuse such as jumping, grinding or any other type of stunts.

FAILURE TO USE COMMON SENSE AND HEED THE ABOVE WARNINGS FURTHER INCREASES RISK OF SERIOUS INJURY. USE AT YOUR OWN RISK AND WITH APPROPRIATE AND SERIOUS ATTENTIONS TO SAFE OPERATION.

Toy components overview

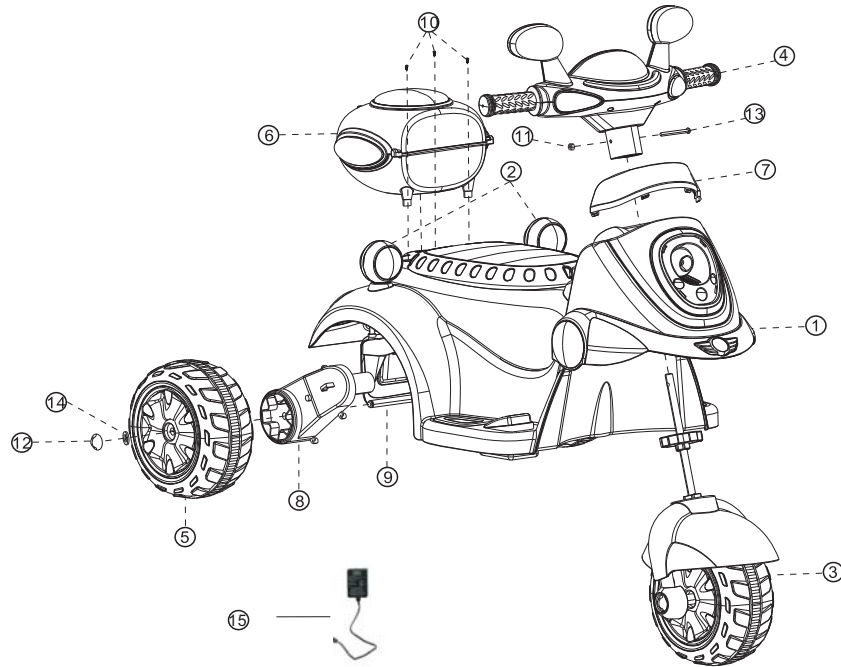

- 1. front panel
- 2. tail lights
- 3. front wheel
- 4. handle bar
- 5. rear wheel
- 6. tool kit
- 7. windshield
- 8. gearbox assembly

- 9. rear axle
- 10. screws
- 11. crew cap
- 12. axle cap
- 13. screw
- 14. washer
- 15. charger

Parts assembly instructions.



1. Assemble the rear mudguard.

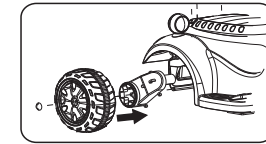

2. Put the gearbox on the rear axle and then assemble the driving wheel.

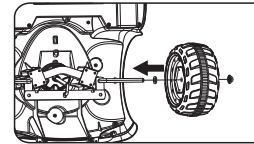

3. Slide a washer on the front axle, then put the wheel onto the axle and make it tight using the axle cap .

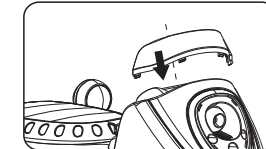

4. Assemble the windshield.

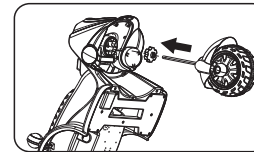

5. Assemble the front wheel set .

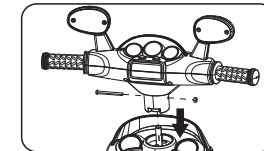

6. Assemble the handle bar on the orientation pole.

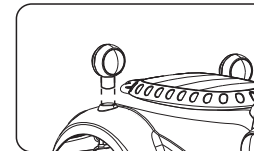

7. Assemble the tail lights.

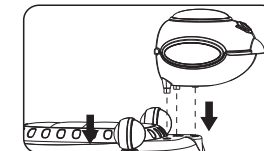

8. Assemble the tool kit at the back.

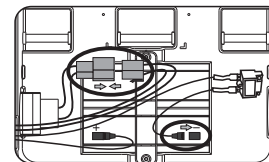

9. Connect the motor to the battery under the saddle.

ELECTRICAL SYSTEM DIAGRAM

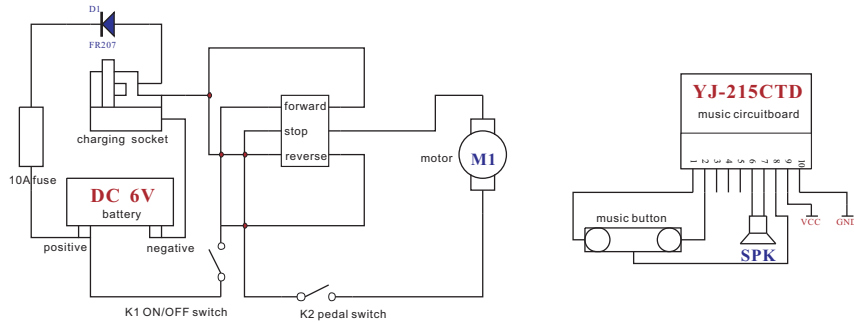

Charging the battery prior to use. Your toy may not have a fully charged battery at the time of purchase. Therefore it is a good idea to charge the battery prior to use.

Plug the charger's plug into the power outlet. Make sure the power on the wall is ON.

Use the battery and charger only specified by our company for safety concerned.

Please Note

Make sure the voltage specification of the charger meets your local compartment

Before charging the battery, please make sure the toy is switched to "OFF" MODE.

PARTS IDENTIFICATION

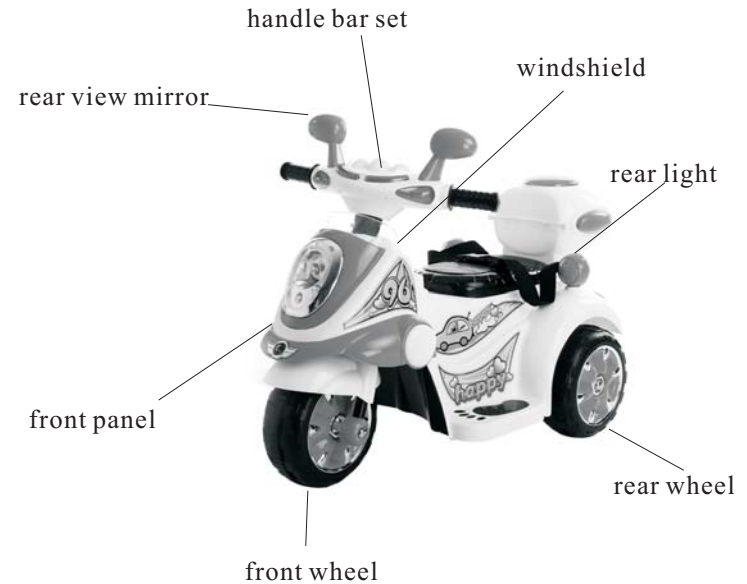

Safety Check Before Riding

There should not be any unusual rattles or sound from loose parts or broken components. If you are not sure, ask an experienced mechanic to check.

Safety

⚠️ **WARNING:** Maintain a hold on the handlebars at all times.

⚠️ **WARNING:** Do not ride more than one person at a time. Never use near steps or swimming pools.

⚠️ **WARNING:** Not suitable for children under 36 months due to small parts.



WARNING TO PARENTS: Kids need to be taught and be frequently reinforced of the importance of safe riding, the rules of the road and the importance of avoiding using the toy on streets due to dangers and hazards of traffic, especially motor vehicle traffic. Parents and children are urged to read and understand these safety tips together.

Ride defensively. Assume that pedestrians and others are so absorbed in their own world that they are not paying any attention to you and that they will run you down or step out in front of you, all without any warning.

Watch for obstacles such as pot holes, sewer grates, expansion cracks, and road or construction debris (such as nails or other foreign objects) that could catch your wheel or force you to swerve into traffic or lose control.

Never carry a passenger.

Never hitch a ride with another vehicle.

Riding a toy car may be a hazardous activity and has inherent dangers that no amount of care, caution, instruction or expertise can eliminate. Certain conditions may cause the equipment to fail without fault of the manufacturer. Activities involving the use of electric vehicles carry the risk of injury or death.

The transformer/charger supplied with the go cart should be regularly examined for damage to the cord, plug, enclosure and other parts, and, in the event of such damage, the scooter must not be charged until it has been repaired or replaced.

Warnings

It is important to read and follow all the instructions and safety information contained in this Operation Manual prior to use.

- Do not operate at night
- Comply with all local laws and regulations
- Do not use in wet conditions
- Do not ride in off-road conditions
- Make sure the environment is safe for riding
- Recommend for riders 36 months and up
- Ensure battery is properly charged before use
- Do not ride on sloped areas
- Do not expose the charger on moisture or water
- Do not leave the power on when not in use
- Do not modify any parts
- Practice riding the toy in a large, open area
- Do not ride through standing water, in sand, mud, hilly or low visibility conditions.
- Never ride near streets, swimming pool, hills, steps, sloped driveways or motor vehicles. And watch your surroundings for pedestrians, bikes, and skateboard and scooter rides.
- Non-rechargeable battery can not be charged.
- The battery chargers used with the toy are to be regularly examined for damage to the cord, plug, enclosure and other parts, and in the event of such damage, they must not be used until the damage has been repaired.
- The appliance is intended to be assembled by an adult.
- Rechargeable batteries are only to be charged under adult supervision
- Battery must be inserted with the correct polarity.
- Exhausted batteries are to be removed from the toy.
- The supply terminals are not to be short-circuited.
- Different types of batteries or new and used batteries are not to be mixed.

PROBLEMS AND SOLUTIONS

PROBLEM	POSSIBLE CAUSE	SOLUTION
Vehicle does not run	Uncharged battery	Charge the battery, A new battery should have been charged for at least 8 hours before using the vehicle for the first time. After first-time use, recharge the battery for at least 8 hours after each use. Never charge the battery longer than 10 hours. Check all connectors. Make sure the charger connector is plugged into the battery, and that the charger is plugged into the wall. Make sure the power flow to the wall outlet is ON.
	Charge is not working	There is no sure way to tell if your charger is working unless you have a volt meter. If you suspect there is a problem with your charger contact authorized service center. They can test your charger for you.
	Tripped fuse	The built-in fuse may "trip" and shut down operation of the vehicle if the vehicle is overloaded or the driving conditions too severe. Once a fuse has "tripped", remove your foot from the pedal and replace the fuse with spare. To avoid repeated automatic shutdowns, do not overload the vehicle by exceeding the 25 kg maximum weight capacity or by towing anything behind the vehicle. Do not drive up hills or run into fixed objects which can cause the wheels to stop spinning while power is still being supplied to service center.
	Loose wire or loose connectors	Check all wires and connectors. Make sure the motor harness Connector is plugged into the battery, and that there are no loose wires around motors
	Dead battery	If your battery is old or if you have not followed Battery care instruction, your battery may be dead, you can have it tested at service center
	Electrical switch damage	The electrical switches can become corroded due to exposure to water or moisture, or can jam due to loose dirt, sand or grave
	Motor damage	Contact your local service center for diagnosis and repair
Vehicle was Running but Suddenly stopped	Tripped fuse	The built-in fuse may "trip" and shut down operation of the vehicle if the vehicle is overloaded or the driving conditions too severe. Once a fuse has "tripped", remove your foot from the pedal and replace the fuse with spare.

PROBLEM	POSSIBLE CAUSE	SOLUTION
Short run time (less than 0.5 hour per charge)	Uncharged battery	Charge the battery .A new battery should have been charged for at least 8 hours before using the vehicle for the first-time use,recharge the battery for at least 8 hours after each use.Never charge the battery longer than 10 hours.
	Over charged battery	Do not charge the battery longer than 10 hours. If you suspect that your battery is damaged as a result of over charging .connect service center. They can test your battery for you.
	Battery is old will not accept full charge	Even with proper care,a rechargeable battery does not last forever .Average battery life is 1 to 3 years depending on vehicle use and use conditions .replace the battery with 1 new 6 volt rechargeable battery.do not substitute parts.
	Tripped fuse	The built-in fuse may “trip”and shut down operation of the vehicle if the vehicle is over loaded of the driving conditions too severe.once a fuse has “ tripped ” ,remove your foot from the pedal and replace the fuse with spare.To avoid repeated automatic shutdowns,do not over load the vehicle by exceeding the 25 KGS . Maximum weight capacity or by towing anything behind the vehicle .Donot drive up hills or run into fixed objects,which can cause the wheels to stop spinning while power is still being supplied to the motors . If a fuse continually trips , contact service center.
Vehicle runs sluggishy	Uncharged battery	Charge the battery . A new battery should have been charged for at least 8 hours before using the vehicle for the first-time use.After the first-time use,recharge the battery for at least 8 hours after each use .never charge the batter longer than 10 hours.
		Check all connectors. Make sure the charger connector is plugged into the battery and that the charger is plugged into the wall.
		Be sure to charge the battery after each use
	Battery needs charging	Even with proper care,a rechargeable battery does not last forever. Average battery life is 1 to 3 years depending on vehicle use and use conditions .replace the battery with a new 6 volt rechargeable battery.do not substitute parts
	Battery is old and will not accept full charge	Even with proper care,a rechargeable battery does not last forever .Average battery life is 1 to 3 years depending on vehicle use and use conditions .replace the battery with a new 6 volt rechargeable battery.do not substitute parts.
	Vehicle is over loaded	Make sure you do not overload the vehicle by allowing more than one rider at one time ,by exceeding the 25 kg maximum weight capacity,or by towing objects behind the vehicle.
	Driving conditions are too stressful	Restrict your child 's driving to areas that are generally level with gentle inclines or slopes.

PROBLEM	POSSIBLE CAUSE	SOLUTION
Sometimes the vehicle doesn 't run, but other times it does	Loose wire or connector	Check all wires around the motors and all connectors to make sure they are tight.
	Motor or electrical switch damage	Contact service center for diagnosis and repair.
When the foot pedal is pressed,the vehicle won 't run without a push	Loose wire or connector	Check all wires around the motors and all connectors to make sure they are tight.
	“dead spot ” on motor	Contact service center for diagnosis and repair.
Battery 's fuse constantly trips but the vehicle is not over loaded not the driving conditions too severe	Damaged battery	Contact your local service center for diagnosis and repair
	Child is switching between FORWARD and REVERSE without stopping	Teach your child to stop the vehicle before switching direction.
Loud clacking or grinding noise from a motor -gearbox	Broken battery gears	Contact service center for diagnosis and repair.
Charger gets warm during use	It is normal for some charges to get warm during use and is not reason for concern	Not action required
		If your charge does not get warm during use,it does not mean that it is not working properly
Battery makes a sizzling or gurgling noise when charging	It is normal for some batteries to make noise charging and is not reason for concern	Not action required
		If your battery does not make noise or swell slightly during charging,it does not mean that it is not working properly