



HD- FJ526

Maintenance

- .Always checking and keeping the car well to avoid accidental injury of your children.
- .Please check if everything in packing list are there before assembly, contact us if any missing.
- .Check if the screws and parts are good regularly.
- .Check every part if it is good when assemble or use it.
- .Clean the product regularly and carefully that do not damage the electronic component.
- .Please read the manual introduction carefully before assembly to avoid unnecessary damage.



HUADA (FUJIAN) TOY COMPANY LIMITED
 ADD: SUIAN INDUSTRIAL PARK, SUIAN INDUSTRIAL ZONE,
 ZHANGPU, ZHANGZHOU, FUJIAN, CHINA 363200
 TEL: 0086- 596-3282345
 FAX: 0086-596-3282678



INSTRUCTION MANUAL

Please read the manual carefully before using product, pay attention to the important safety warnings and keep this manual for future use.

Execute standard:GB6675 GB19865



Manufactured in China under license from
 quattro GmbH

WARNING

Please read the following warning carefully before assembly.

- *The assembly must be undertaken by adult and assembly should be checked after it finished. And the guardian should read the manual carefully and teach the children to operate with correct method, especially how to brake.
- *This product is not suitable for children who is under 3 years old, and the suitable age is 3 to 6 years old.
- *This product can be disassembled, so playing car must be conducted by guardian, and to avoid children swallow the small parts.
- *The packing bags are not toys and may cause suffocation. Remove all packing materials before giving the product to children.
- *Do not drive this vehicle on public streets, roads, or near dangerous areas, such as steps, slope, water pool, etc. large and smooth square is ideal place for playing the car.
- *This product just only can be loaded one child, and loading capacity is 30 KGS, it can not be overloaded.
- *The child should not stand up or jump during driving, and must put on shoes during driving the car.
- *Seat belt is to increase the safety of children only, it does not have the effect of a seat belt as in real cars.
- *This product is equipped rechargeable battery, please charge it before using, and charging must be undertaken by guardian, the way to charge must be sample as manual stipulates.
- *The remote controller use 3 pcs 1.5V "AAA" (NO.7),and the batteries are not rechargeable, do not charge them. Remove them from the toys when their power is used up. The batteries should be the same, do not combine new and used batteries to use together.
- *Fire danger. Do not use resettable fuses which in unconformity with this product. This product uses 15A fuse. Use the provided fuse to replace the damaged one.
- *Do not use the battery which specification is not suitable for this product. This product is equipped with 12V7Ah battery. The connector must be connected correctly, do not connect them to wrong pole, and connector can not be short circuit. And do not use the connector which is not supplied by us.
- *Please take off the batteries when no use the product for long time , include the batteries of car, remote controller .And do not stock the batteries near fire, heat or wet place.
- *Do not use the charger as toy. It is not a toy.
- *This product contains electronic components. Do not use it in water or wet surroundings. Use wet cloth to clean the plastic surface only, do not wet any electronic parts.

Warranty

- 1, We will help our customers to repair all the products from us.
- 2, If the products are used all as manual introduction said, if the product has quality problems after purchasing in 3 months, the repairing work is free.
- 3, If the products are not used as manual introduction said and cause quality problems, need to charge part repairing cost.
- 4, When you need to repair the product (or spare parts), please take the invoice or warranty card with you.

Repair Record

Date	Problems	Remark

Customer: _____

Telephone: _____

Address: _____

Item No.: _____

Invoice No.: _____

TROUBLESHOOTING GUIDE

Problems	Check if
The vehicle does not move	<ul style="list-style-type: none"> • the battery is connected to the electrical system properly. • the gear is put at either DRIVE or REVERSE position. • the car is overloaded. • the automatic-restore over-current protection device can conduct current.
The vehicle moves slowly	<ul style="list-style-type: none"> • the car is overload. • Charge the battery. If after charging the problem still exist, the battery needs to be replaced.
Voltage indicator does not light up	<ul style="list-style-type: none"> • switch on the vehicle. • battery is out of power.
Battery can not get to full stage	<ul style="list-style-type: none"> • the battery is connected to the electrical system properly. • the charger and the battery are in good condition. • the socket is working. • the anode and cathode of the battery are properly and well connected.
Power ON/OFF button sparking	<ul style="list-style-type: none"> • battery is out of power. • turn off the car. After 10 seconds turn it on and match with the remote controller again.
The vehicle does not work for long time	<ul style="list-style-type: none"> • the battery is out of power. • the battery is damaged and need to be replaced.

WARNING









- *Do not change gear position when the vehicle is moving, only do it when the car is stopped, or it may cause damage to the gear.
- *Check the vehicle every time before use.
- *Some components may be broken caused by improper use.
- *Turn off power every time when finished playing to avoid it's being remote controlled accidentally.
- *The surface of the car is easy to scratch, please keep it away from sharp articles.
- *Do not allow children to touch the wheels and places near wheels to avoid injury. when driving, do not allow other children to step up.
- *To teach your child to hold the steering wheel with two hands and wear the seat belt when driving for safety.
- *To teach your child to step on and release off the accelerate pedal.
- *Do not change the product or the circuit system by yourself. Repair work must be undertaken by the technician only.

Specification







Name	Single Motor	Double Motors
Speed	3-3.5km/h	3-4.5km/h
Battery	6V/7AH*1PCS	12V/7AH*1PCS
Charging Power	Input:100-240V 60/60HZ Output:DC8.3V 1000mA	Input:100-240V 60/60HZ Output:DC15.8V 1000mA
Weight	13.3kg	14.8kg
Carton size	125x65x38.5cm	
Suitable age	3-6 years old	
Loading capacity	30KGS	
Working Temperature	0-40°C	
Charging Time	Charge the battery 8-12 hours, but not exceeding 16 hours per time	

Packing list







Regular components

Name	Picture	QTY	Name	Picture	QTY
Main body		1	Steering Wheel		1
Seat		1	Mirror		1 pair
Windscreen		1	Charger		1
Lubricant		1	Hardware pack		1
Manual instruction		1			

Optional components

Name	Picture	QTY	Name	Picture	QTY
Head PU wheel		1 pair	Rear PU wheel		1 pair
Head LED light PU wheel		1 pair	Rear LED light PU wheel		1 pair
Plastic wheel		4	Plastic wheel cover		4
Remote controller		1			

Hardware pack

	Name	QTY	Picture
A	Screw	1	
B	M5 cap nut	1	
C	Gasket	8	
D	clamp spring	5	
E	Cable	1	
The single motor car need a plastic rear axle sleeve			
	Rear axle sleeve	1	

Charging

To ensure the stability of the voltage of the rechargeable battery, please fully charge before first use. When the battery power goes down, the speed of the car would reduce to very slow. Please stop using the car and recharge the battery at this point.

For charging, please follow instructions below:

- *Battery charging must only be conducted by an adult. Do not allow children to charge or play with the battery.
- *Connect the charger to the charging socket located under the seat. Make sure your local voltage is accordant to the one marked on the charger. Plug the charger to a socket (Indicator on charger lights up when the battery is in charging).
- *When charging the battery and/or the charger would warm up somewhat (below 60°C) which is normal. Higher than this temperature please check if the current is short circuited or over loaded immediately.
- *If the vehicle is left unused for a long period of time, remember to charge the battery and to recharge every three months to prolong the life-span of battery.
- *Do not put the battery in water or fire. Do not disassemble the battery.
- *Do not turn on power when charging. When charging, the vehicle must be set to power OFF.
- *Only use the battery and charger provided or recommended by us. Do not play with battery and charger, they are not toys.
- *Regularly inspect the charger to check the cable, plug, shell box and/or any other components are in good conditions. If found damaged, please do not use it until repair is undertaken.
- *If there is smoke, smell, noise, etc., stop charging immediately and send for repair.
- *Do not disassemble the battery or the charger.
- *For security, do not take away the fixed rechargeable battery when replace the battery.

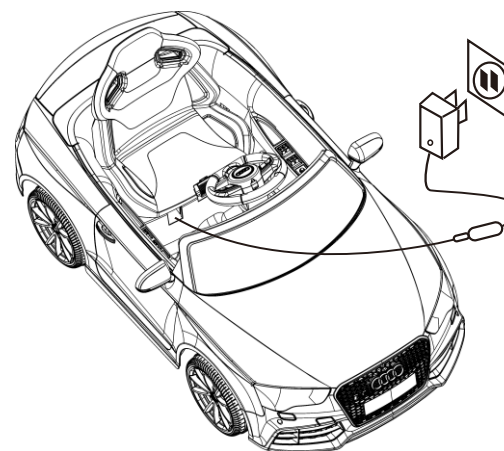

WARNING

THIS PRODUCT IS WITH CHARGING PROTECTING FUNCTION AND WHEN CHARGING, DO NOT SWITCH ON THE VEHICLE!

Functions and Usage introduction

The matching is finished in factory. After finishing assembly by correct method, the car will have following functions:

*Emulational gear equipped, push the gear up, first time is "D1" low speed, and second time is "D2" high speed; Pull the gear down is REVERSE GEAR; Whenever you press the "N" button, the car will be stationary. When it is "D1" or "D2", step on the accelerator pedal, the car moves forward; When it is "REVERSE", step on the accelerate pedal, the car moves backward; When it is "N", step on the car will not work. When the car is controlled by remote controller, the accelerator will be not workable, and the remote controller must be handled by adult to avoid unexpected hurt.

*The car can be connected to MP3 player. The steering wheel no sound when it is connected to MP3, the volume is adjustable. Note: take off the MP3 cable when not use it, if not, it will effect the other sounds function.

*The front wheels of electrical steering car can back in to straight automatically after turning right/left by remote controller; and the mechanical steering car will stay in the potion after turning right/left by remote controller.

* If want to use new remote controller, need to rematch the remote control code as follows: Step 1, turn on the car power; Step 2, turn on the remote controller power; Finally, Press the 3-speed button and hold for 5 seconds. The matching is finished.

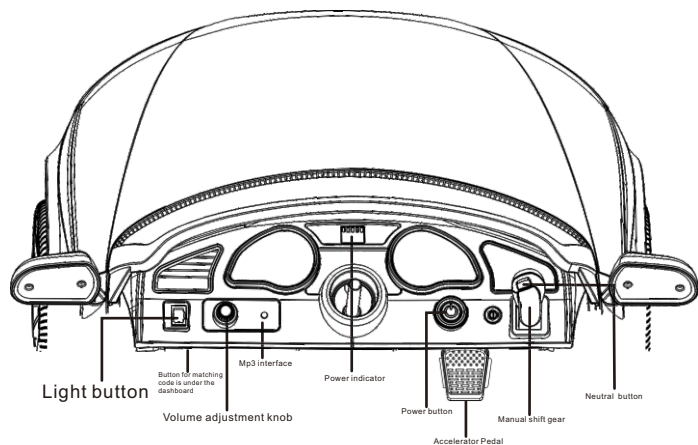

The assembly for components

Notice: The assembly of components need screw driver(not included), must be handled by adult.

1.1, Wheel assembly, as Fig. 1 shown, take off the protection covers at the end of the axles, and paste the lubricant on the end of axles.

1.1.1, Plastic wheel assembly:

a, For head wheels: Put gasket, wheel, gasket into the axle, and clasp with a clamp spring(as Fig2.), finally put on the wheel cover to the wheel. Both sides are the same.

b, For rear wheels: Put in order gasket, wheel, gasket into the axle, and clasp with a clamp spring(as Fig2.), finally put on the wheel cover to the wheel. Both sides are the same.

c, Rear wheels assembly of Single motor: Right side is the same method as double motor; Put in order rear axle sleeve, wheel, gasket into the rear axle, and clasp with a clamp spring, finally put on the wheel cover to the wheel.

1.1.2, PU wheel assembly:

a, Head wheels assembly: put the PU wheel into the axle, press the middle button on the wheel, release the button when the position is correct(As Fig.3). Both sides are the same.

b, Rear wheels assembly: put the PU wheel into the axle, press the middle button on the wheel, release the button when the position is correct. Both sides are the same. *If the wheel is LED light wheel, fit the "+" and "-" pole of LED light wheel to the "+" and "-" pole of motors.

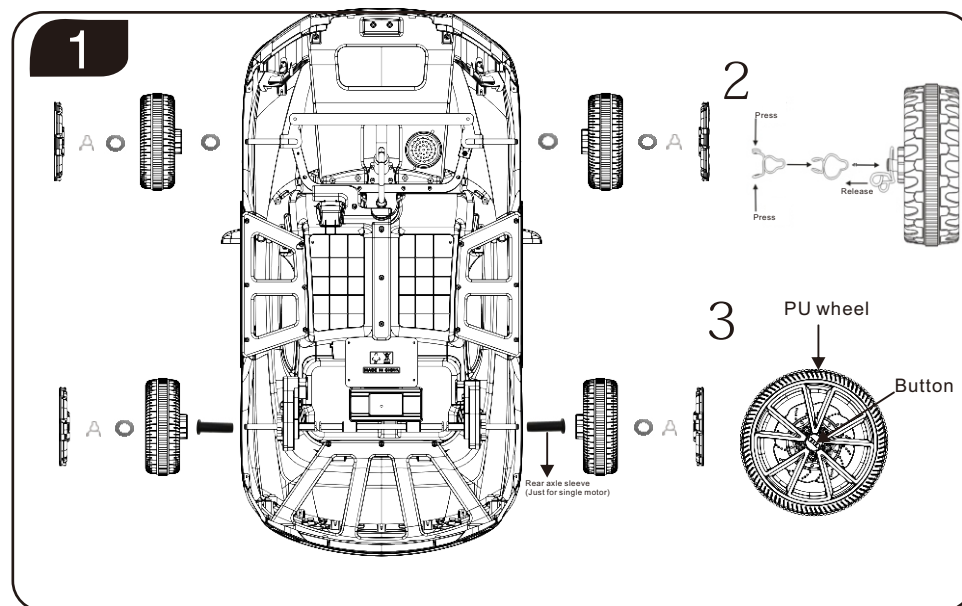

The assembly for components

1.2, Components assembly, as Fig. 4 shown:

1.2.1, Put the windscreen into the slots as Fig shown.

1.2.2, Put the right and left mirrors into the slots.

1.2.3, Connect the cable of steering wheel to the cable of dash board (mechanical steering has one cable, and electronic steering has two.); Second, fit the steering wheel into the steering tube, use screw and nut to secure them, As Fig. 4.

1.2.4, When you choose electrical steering car, there is a adjusting knob on the dashboard: when the steering wheel back in automatically and moving forward is not straight enough, use this knob to adjust it. For example, if the steering wheel back in, but the car moving left, turn the knob to right to adjust it.

★ Take off the battery if not use for long time.

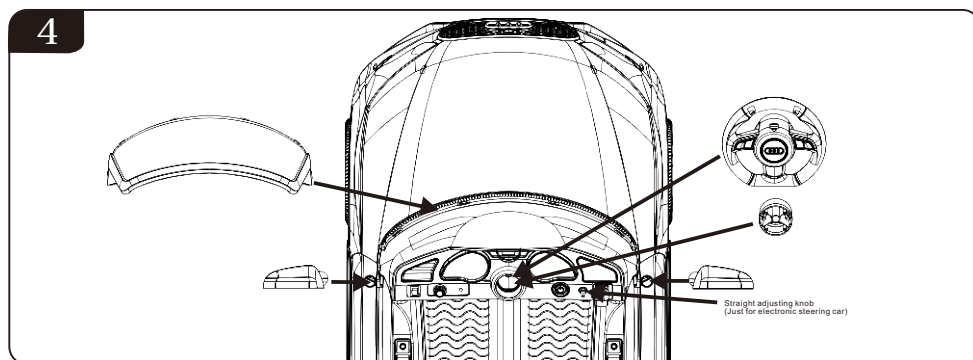

Assemble the seat

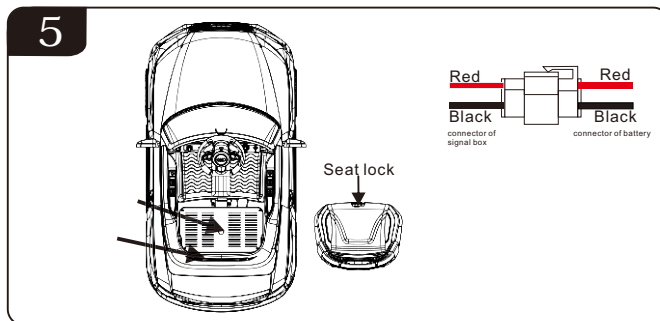

As Fig. 5 shown: Connect the cable of battery to car (Note: Need to connect the same color line); Put the seat into the slot as Fig. Shown, adjust and lock the seat into correct position (As above Fig. Shown: Push left to lock and push right to release).

Functions and Usage introduction

1. Steering wheel

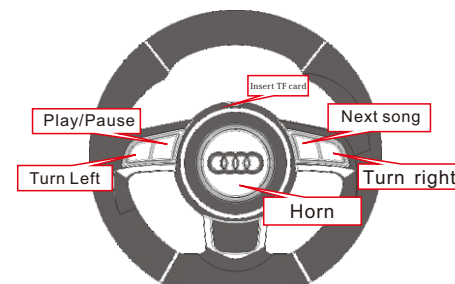

2. Remote Controller

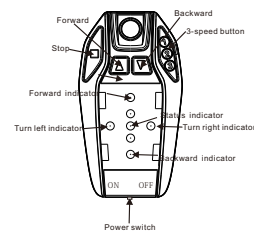

As Fig. shown:

- 1) Remove the battery cover and put into 3 pcs 1.5V“AAA” batteries.
- 2) When the remote controller is power on and car is power off, the R/C indicator light blinks. When both of them power on and indicator light lights, the match is finished.
- 3) 3-speed Button. 1-low speed; 2-middle speed; 3, high speed.

Notice: If the remote controller has been matched, and the indicator light blinks, it need to change the batteries. Please use same battery, do not mix new and old ones, or different brand batteries.