

# Magnetic Manual-MB296

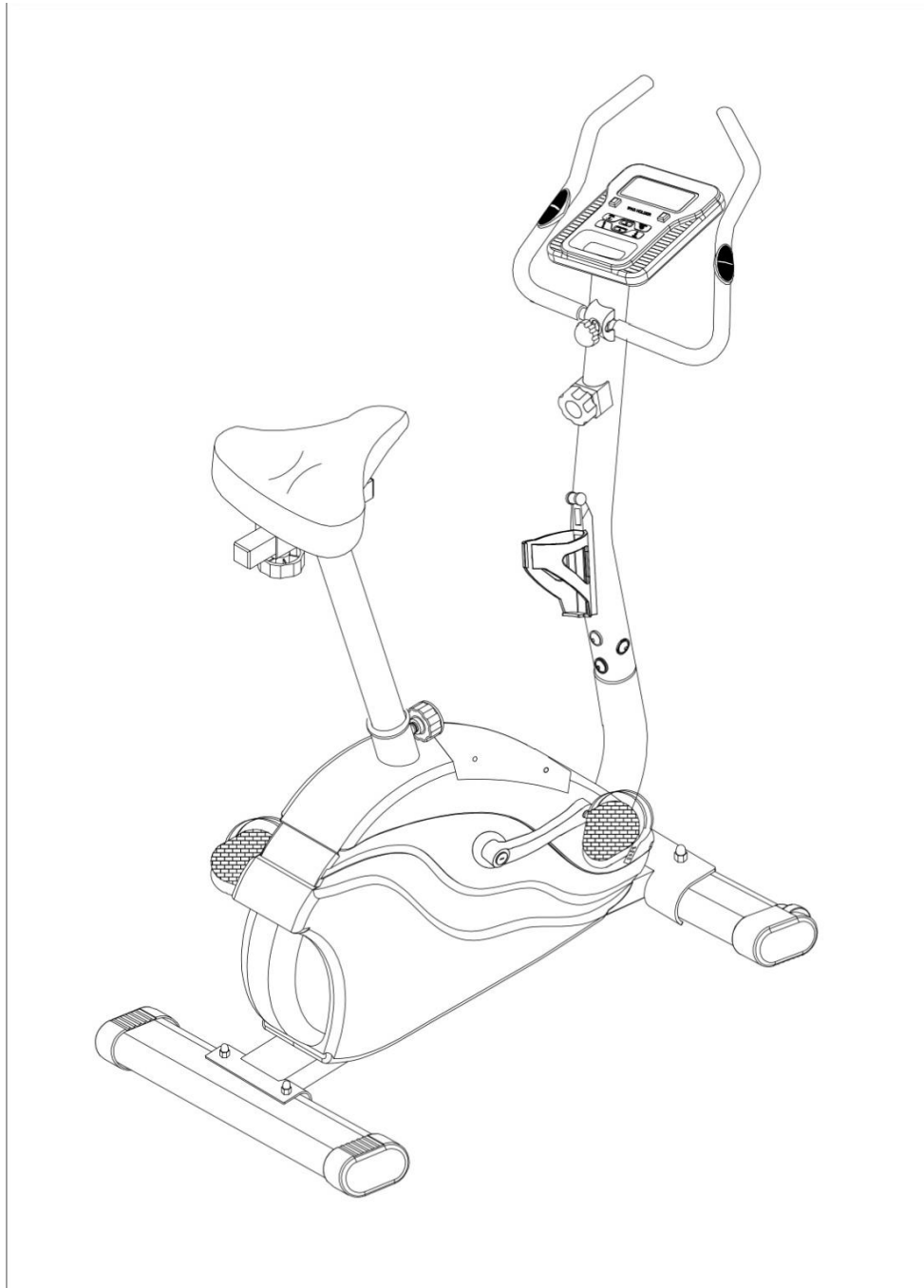

**BEDIENUNGSANLEITUNG**  
INKLUSIVE MONTAGEANLEITUNG

# Zusammenbau

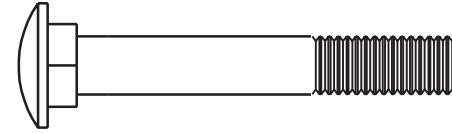
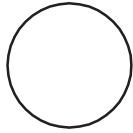
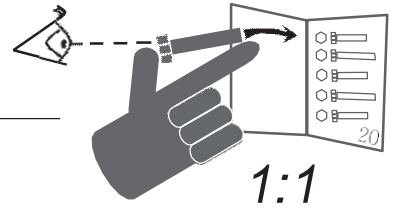
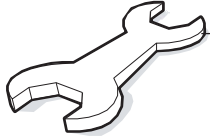

NO.30  
Anz.4

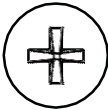

NO.19  
Anz.4

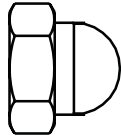
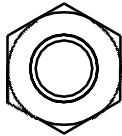

NO.29  
Anz.4



NO.32  
Anz.1

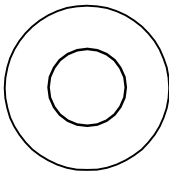

NO.31  
Anz.4



NO.17  
Anz.1

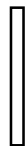
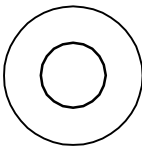

NO.20  
Anz.4

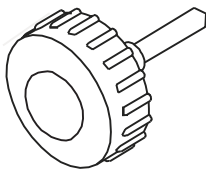

NO.21  
Anz.1



NO.25



NO.22  
Anz.1

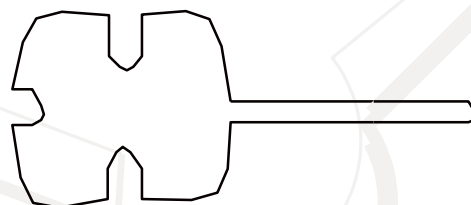

NO.27

# Zusammenbau

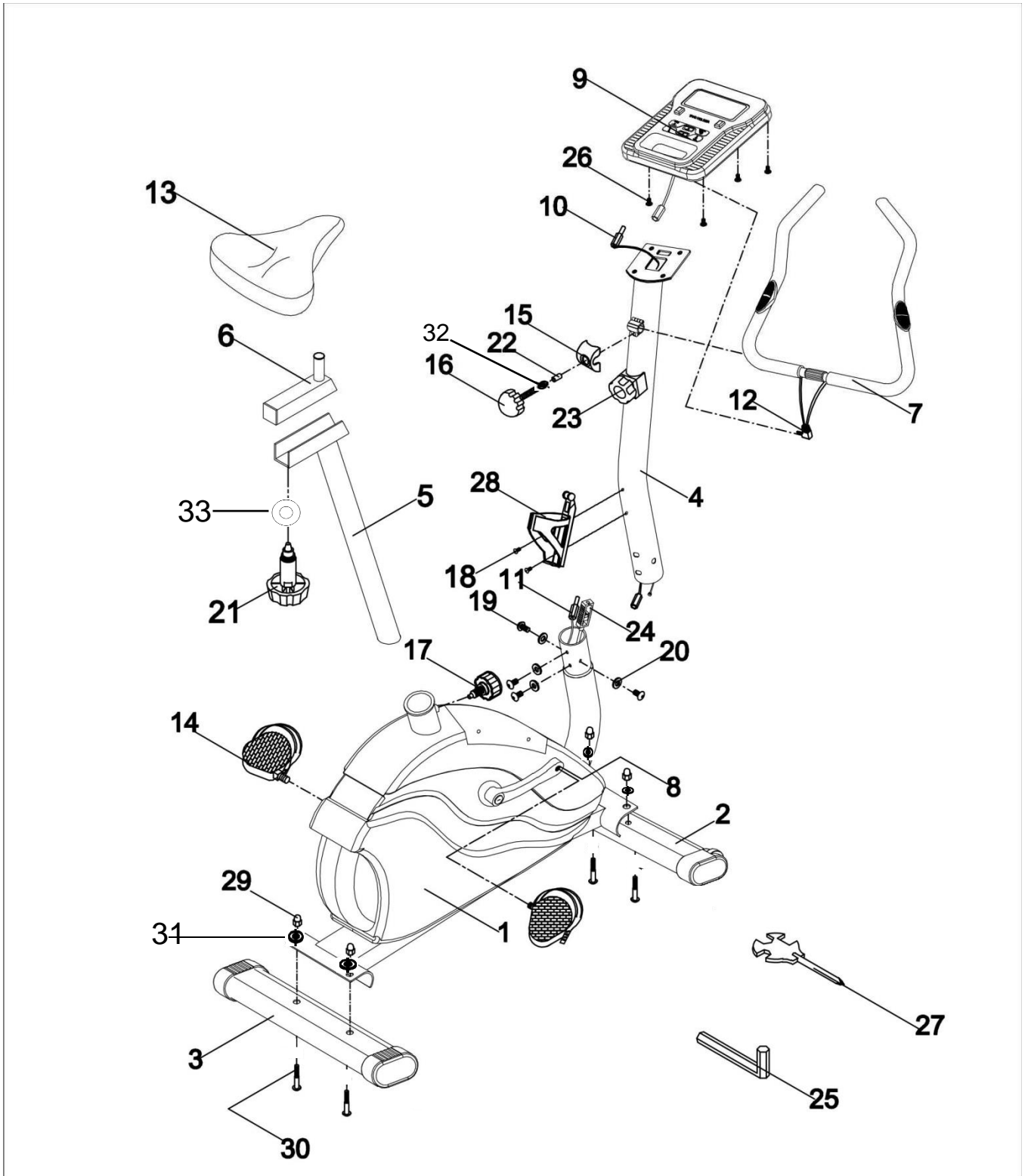
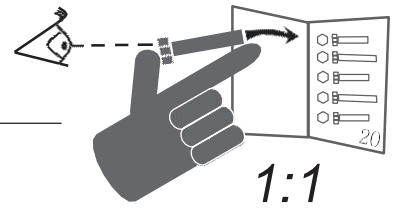
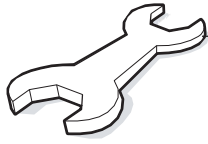

# Zusammenbau

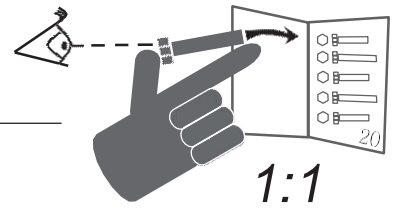

1:1

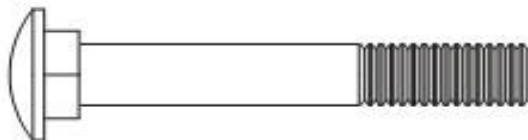
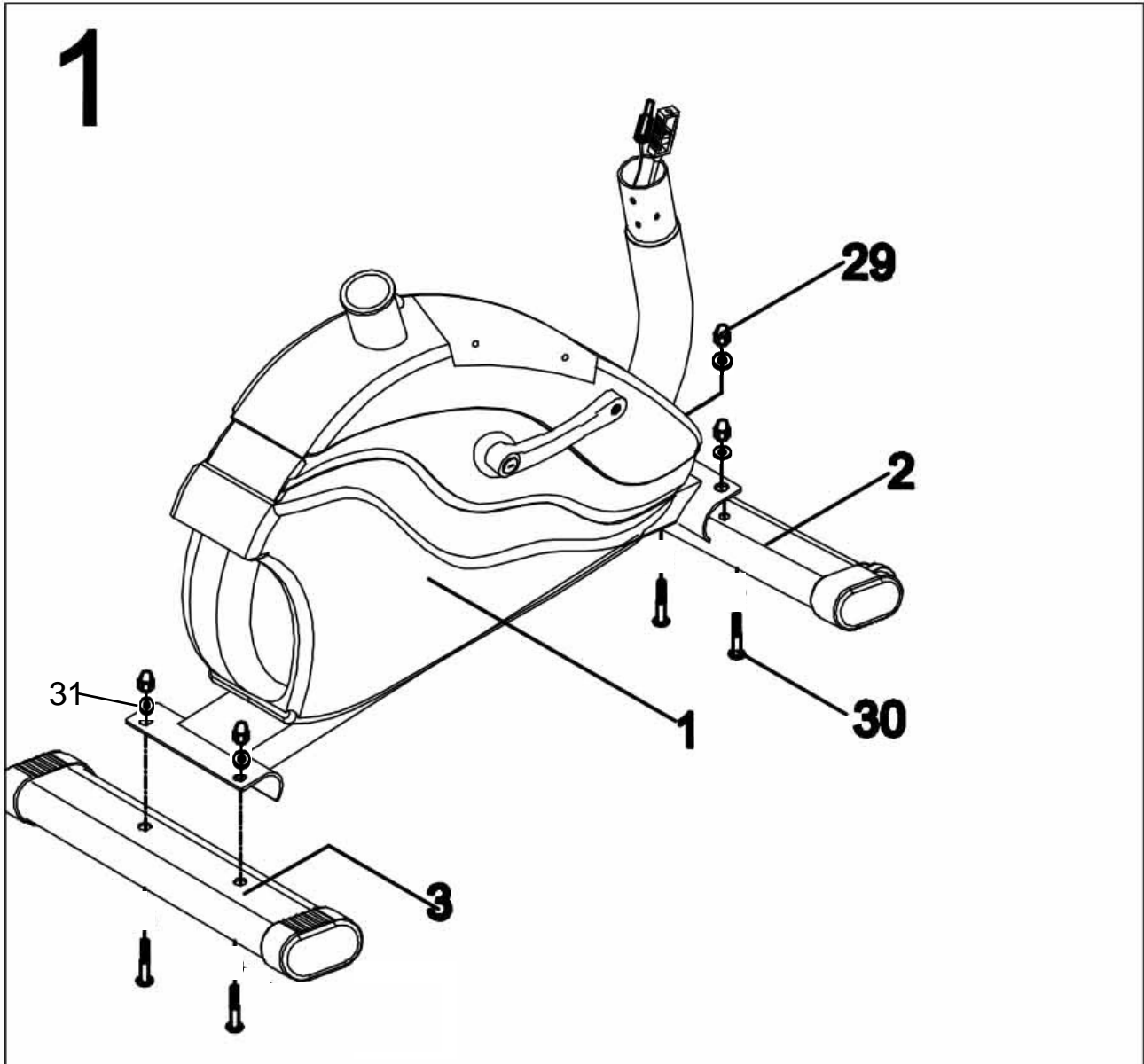

NO.30  
Anz. 4

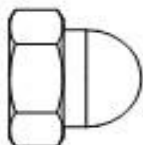

NO.29  
Anz. 4

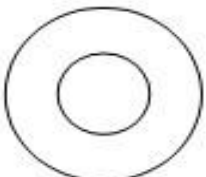

NO.31  
Anz. 4

# Zusammenbau

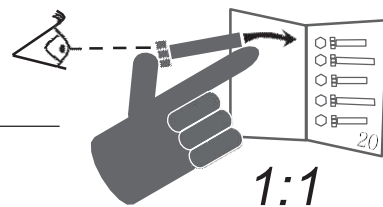

# 2

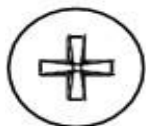
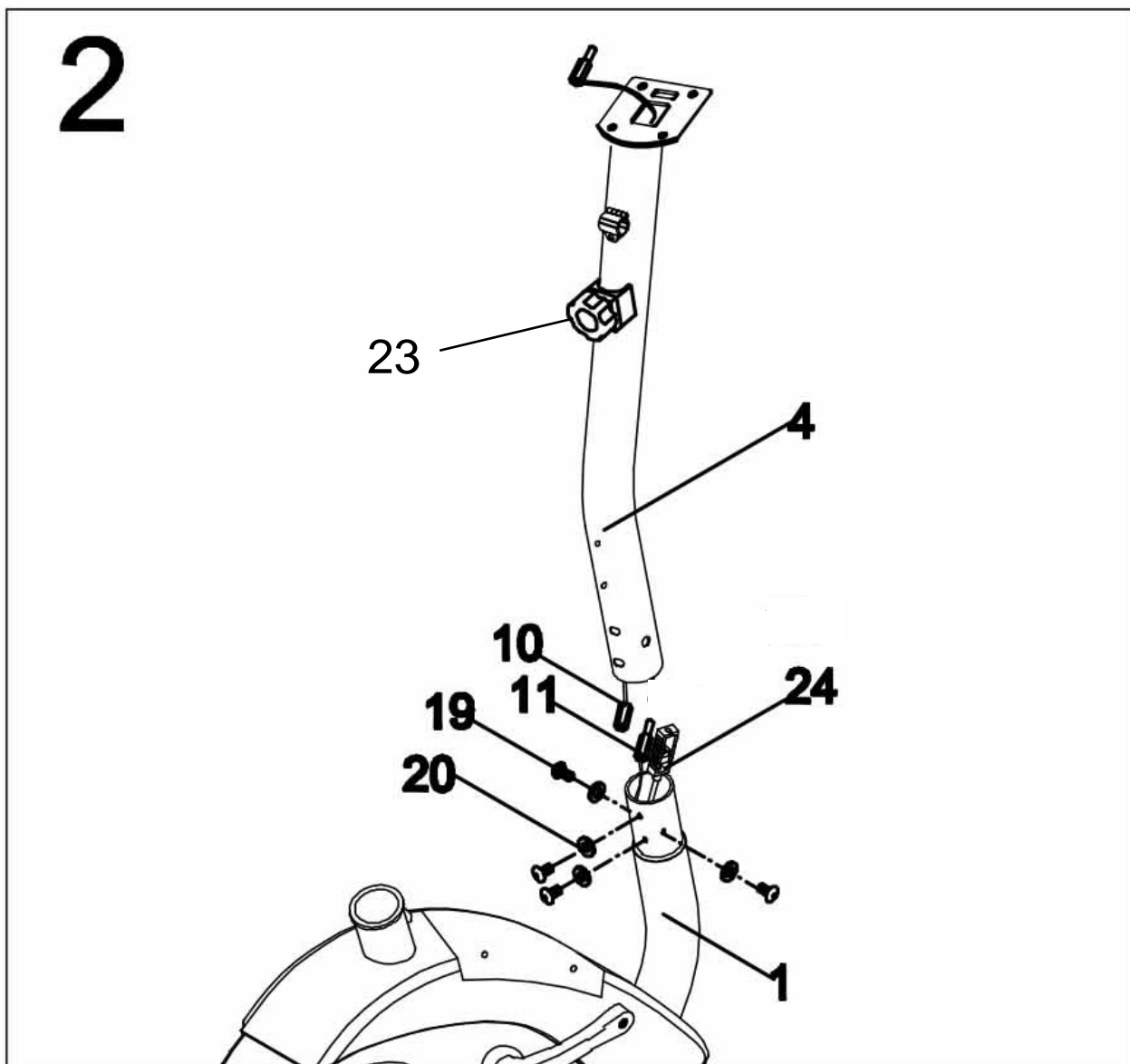

NO.19  
Anz. 4

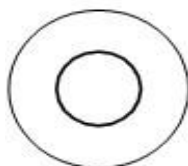

NO.20  
Anz. 4

# Zusammenbau

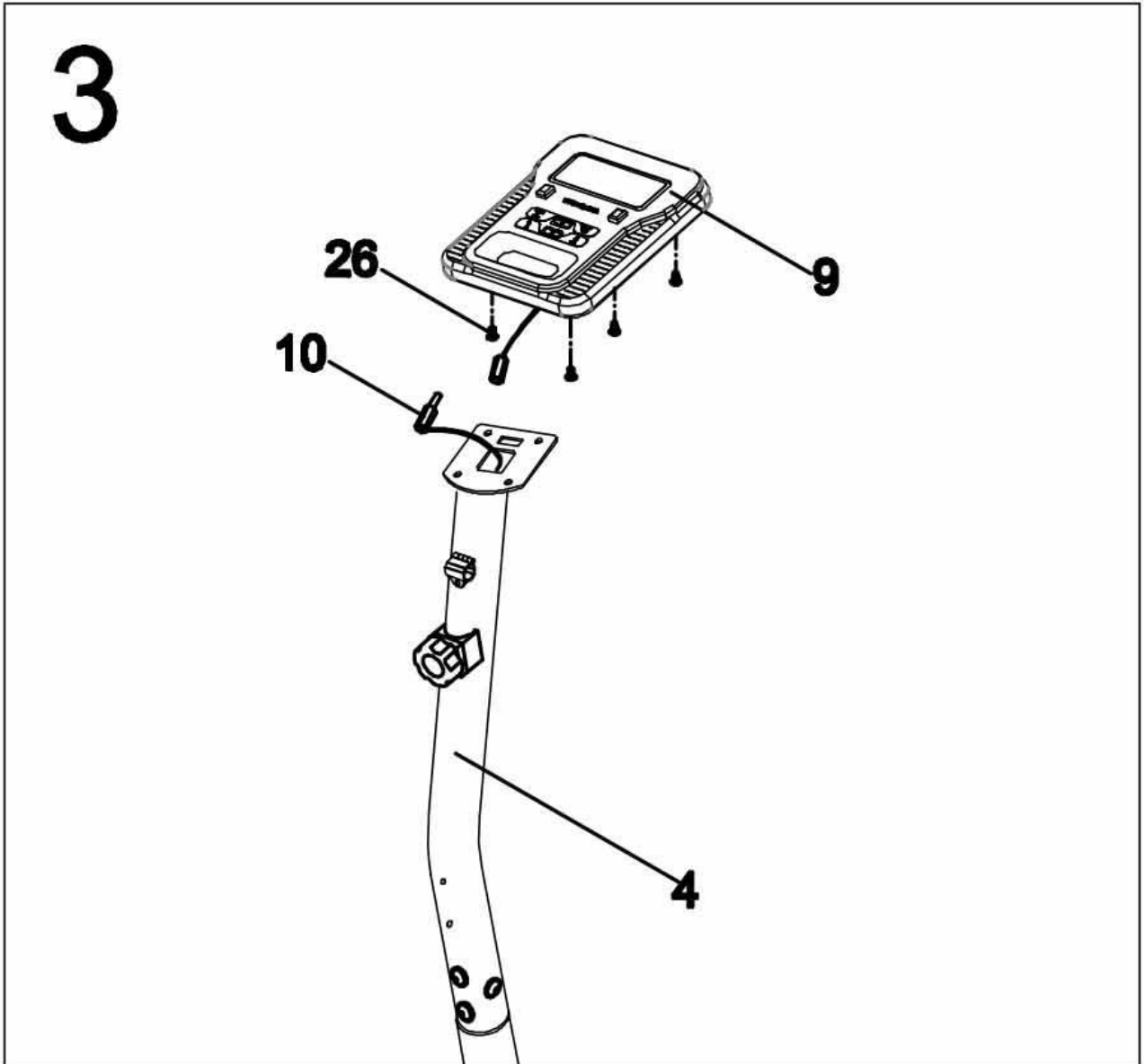
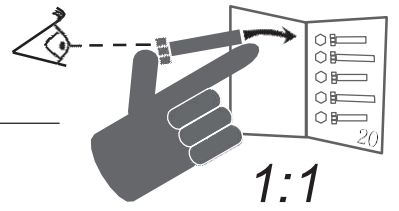
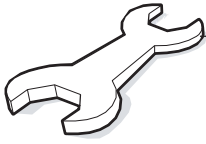

# Zusammenbau

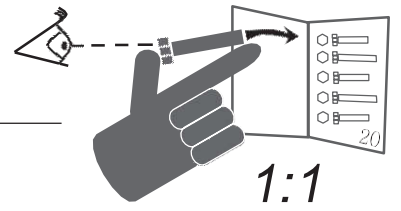
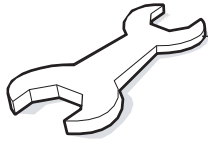

# 4

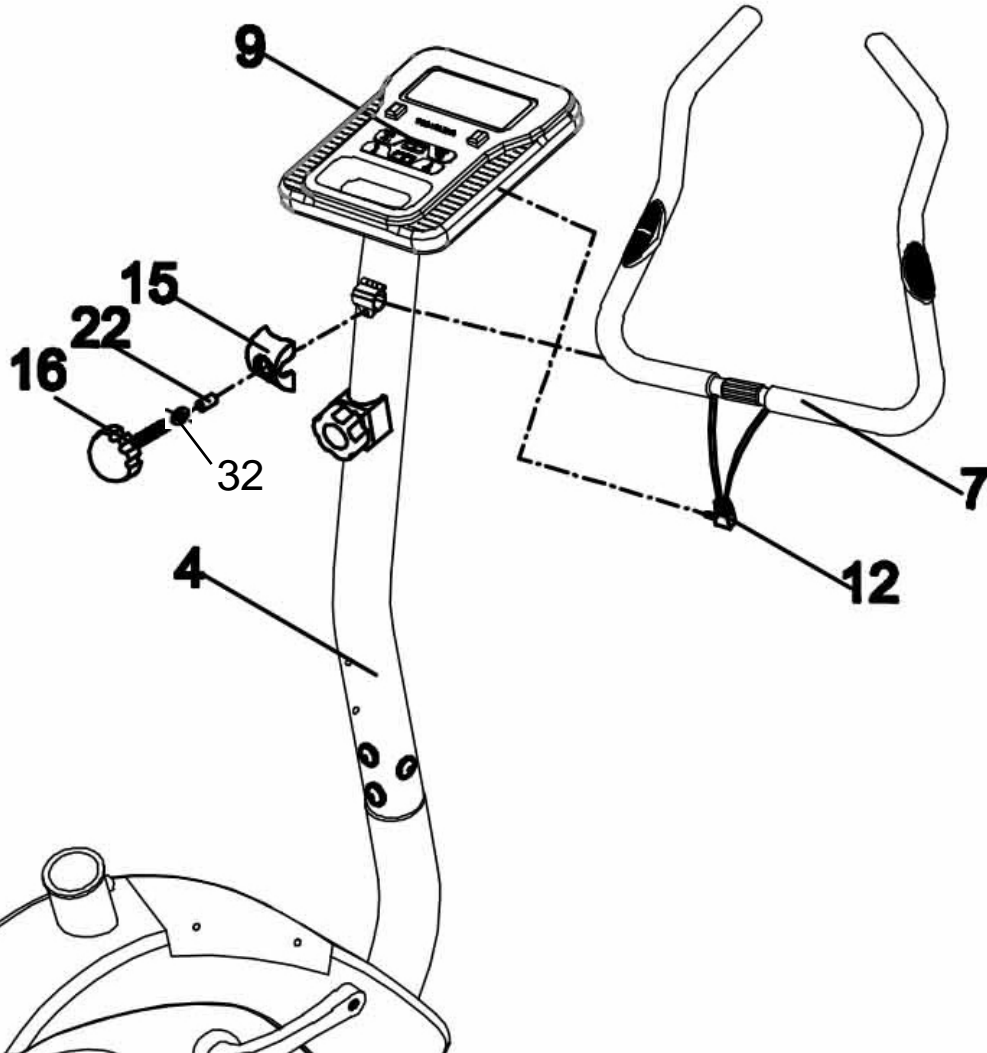



# Zusammenbau

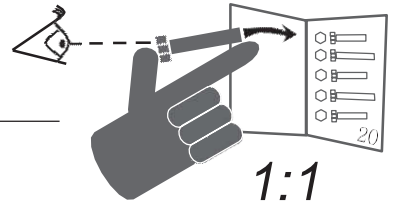

# 5

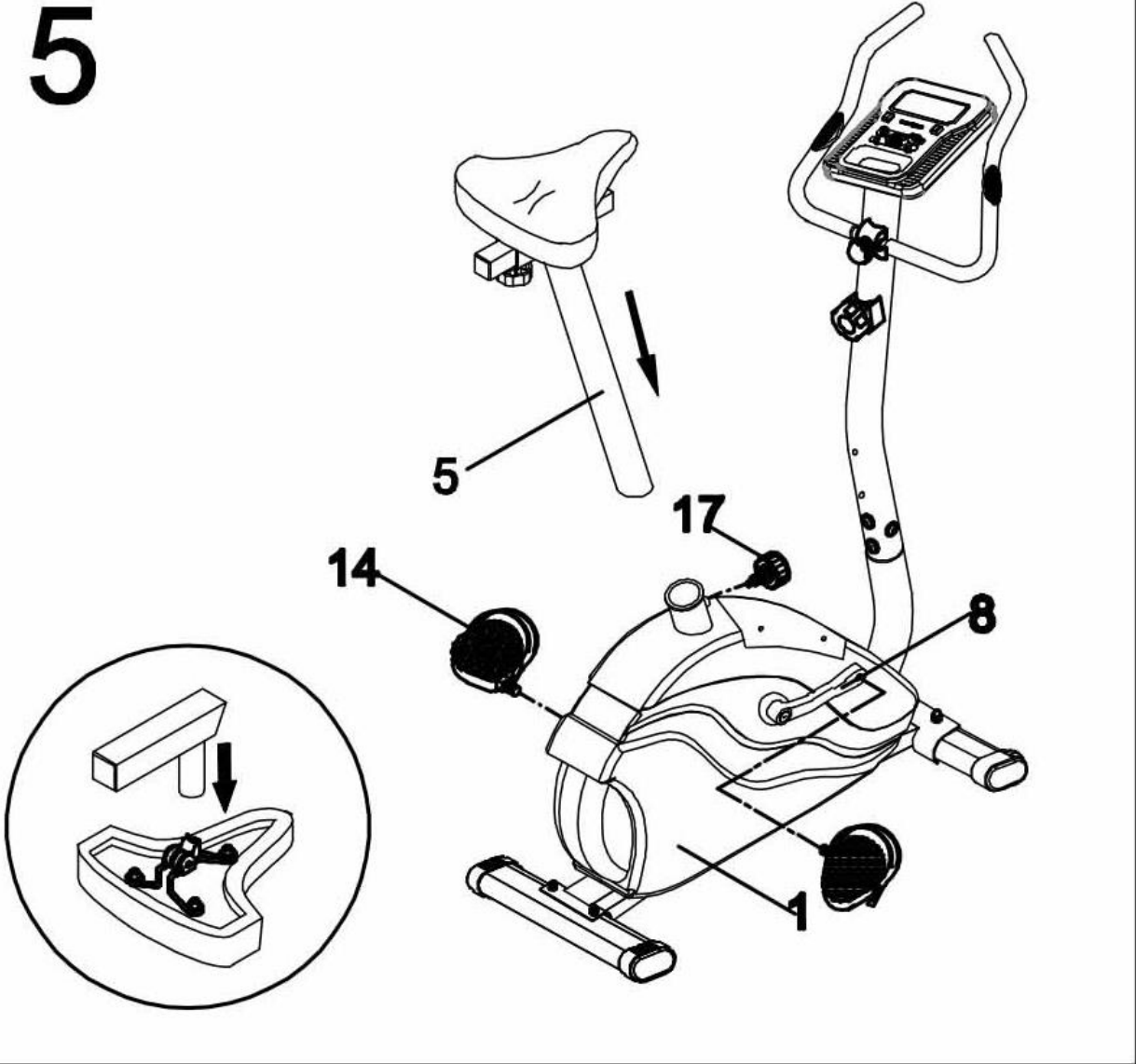



# Zusammenbau

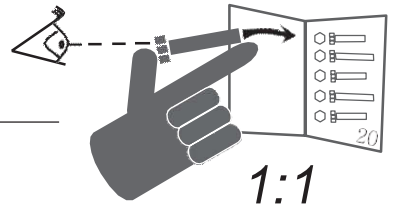

**6**

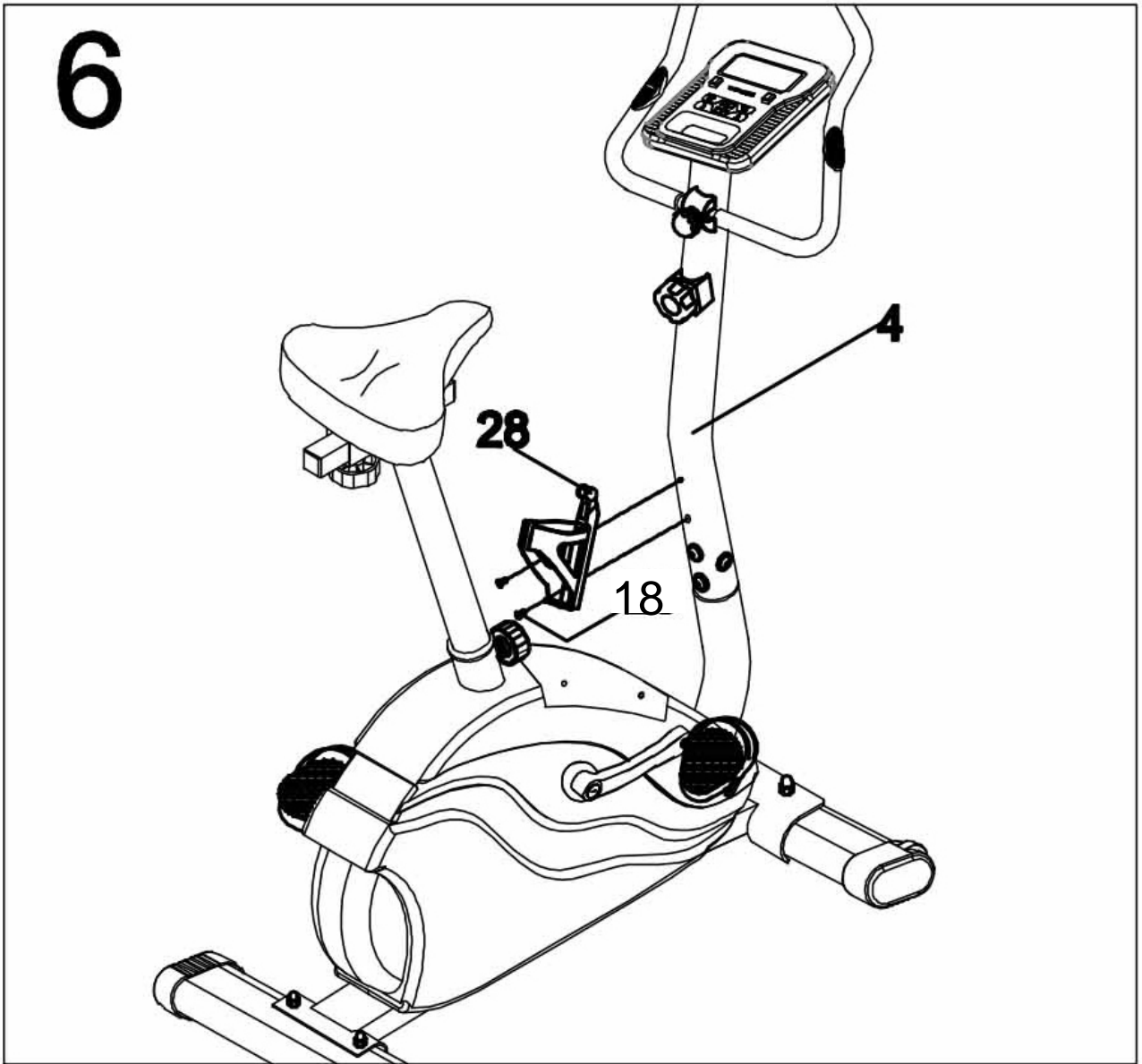

# Zusammenbau

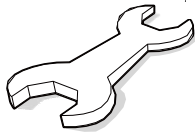

## TEILELISTE

No.	Beschreibung	Anzahl
1	Haupttrahmen .....	1
2	Vorderer Ausgleichfuß .....	1
3	Hinterer Ausgleichfuß .....	1
4	Lenkstange.....	1
5	Sattelstütze .....	1
6	Sitzhalterung .....	1
7	Lenkstange.....	1
8	Kurbel (L/R) .....	2
9	Computer .....	1
10	Oberes Sensorkabel .....	1
11	Unteres Sensorkabel .....	1
12	Pulskabel.....	1
13	Sattel.....	1
14	Pedal (L/R) .....	2
15	Abdeckung Computer(unten) .....	1
16	Lenkerschraube.....	1
17	Sattelpfostenknopf.....	1
18	Schraube (M5x10) .....	2
19	Sechskantschraube (M8x15) .....	4
20	Federring (Φ8x Φ22x1.5).....	4
21	Sattelknopf .....	1
22	Haltestangenunterlegscheibe .....	1
23	Widerstandskontrolleknopf.....	1
24	Spannhaken .....	1
25	Inbus-Schlüssel .....	1
26	Schraube (M5x10) .....	4
27	Kreuzschlüssel .....	1
28	Flaschenhalter.....	1
29	Hutmutter (M8) .....	4
30	Torbandschraube (M8x55).....	4
31	Federring(Φ8x Φ22x1.5).....	4
32	Federring (Φ8x Φ16 x1.5).....	1
33	Federring.....	1

### Hinweis

Manche Teile sind bereits vormontiert.