

BMW i8 Concept RIDE-ON

With remote control function



Owner's Manual with Assembly Instructions

Styles and colours may vary.
Made in China.

The owner's manual contains important safety information as well as assembly, use and maintenance instructions.

The Ride-on Car must be assembled by an adult who has read and understands the instructions in this manual.

Keep the package away from children and dispose of properly before use.

Keep this manual for future reference.

On the purchase of your new Ride-On.

This ride-on car will provide your child with many miles of riding of enjoyment. To help assure you and your rider a safe ride we ask you to please read this manual carefully, and keep it for future reference.

Follow the recommendations in this manual, they are designed to improve the safety and operation of your ride-on car and rider.

Battery	6V4Ah x 1	6V4Ah x 2	
Fuse	7A	10A	
Charger	6V500mA	12V1000mA	

Suitable age: 37~96 Months

Load Capacity: Under 30 kgs

Speed: **1WD** 2.5km/h **2WD** 2.5~5km/h

Size of car: 110 x 61 x 49 CM

Power way: Charging type

Charge time: 8 ~ 12 hours

Parts List | 2

PART NO.	PART NAME	Q'ty (pcs)		REMARKS
		1WD	2WD	
1	Gear box	1	2	
2	Driving wheel	1	2	
3	Normal wheel	3	2	
4	Ø10 washer	4	2	
5	Bushing	3	2	
6	Motor hood	1	2	
7	Ø12 washer	4		
8	Ø10 lock nut	4		
9	Front axle	1		
10	Rear axle	1		
11	Windshield	1		
12	View mirror	2		One pair
13	Seat	1		
14	M5x12 machine screw	2		
15	Steering wheel	1		
16	Ø5 nut	1		Placed on the steering wheel
17	M5x40 machine screw	1		Placed on the steering wheel
18	Steeringh column	1		
19	Charger	1		
20	Engine	1		
21	Vehicle body	1		
22	Side support	2		
23	Ø4x12 screw	12		
24	Remote controller	1		

Assembly package

A	Hubcap	4		
B	Ø4x12 screw	14	18	
C	Split pin	2		1 pc for spare
D	Ø10 washer	3		1 pc for spare
E	Spanner	2		
7	Ø12 washer	2		For spare
F	Ø5 nut	1		
G	M5x20 machine screw	1		
H	R/C driver	1		

NOTE: Some parts shown are assembled on both sides of vehicle

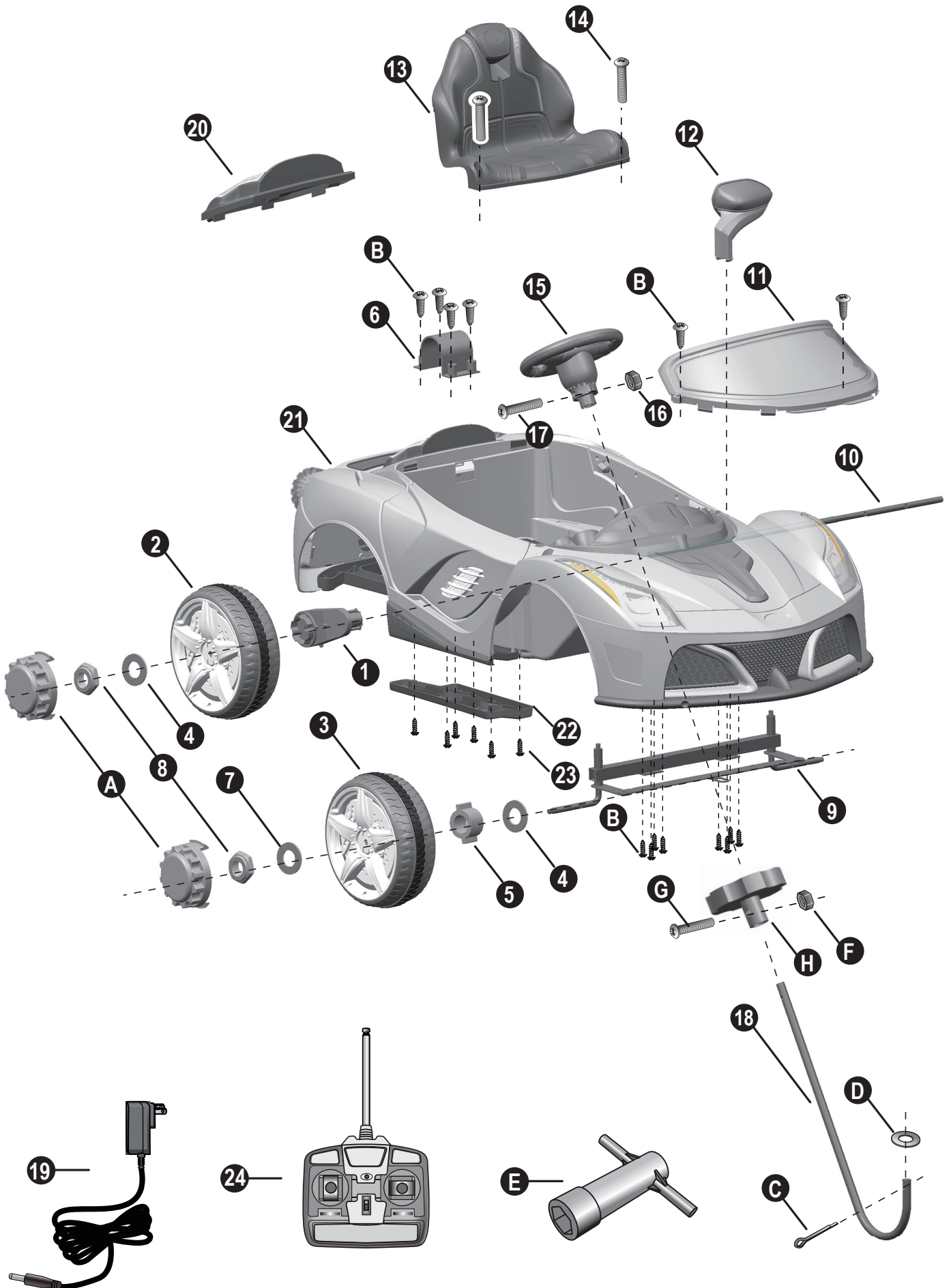



WARNING!

FOR THE SAFETY OF YOUR CHILD, PLEASE READ ALL WARNINGS AND ASSEMBLY/USE INSTRUCTIONS. KEEP THIS GUIDE FOR FUTURE REFERENCE.

- **ADULT ASSEMBLY REQUIRED.** The product contains small parts, which are for adult assembly only. Keep children away when assembling.
- Always remove protective material and poly bags and dispose before assembly.

- Make sure that the power switch is **turned “OFF”** before assembling the ride-on.
- Before first time use, charge the battery for at least 4 to 6 hours.
- Assembly tools required:

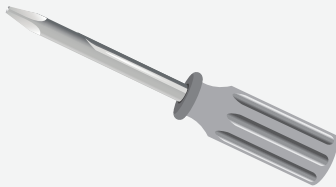

Screwdriver
(not included)

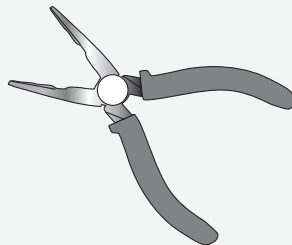

Long nose pliers
(not included)

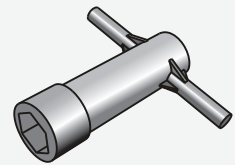

Spanner

Turn the vehicle body upside down.

1. Fit the side support to the vehicel body.
2. Using 6 Ø4x12 screws to secure the side support to the vehicle body with a screwdriver.

Repeat for the other side.

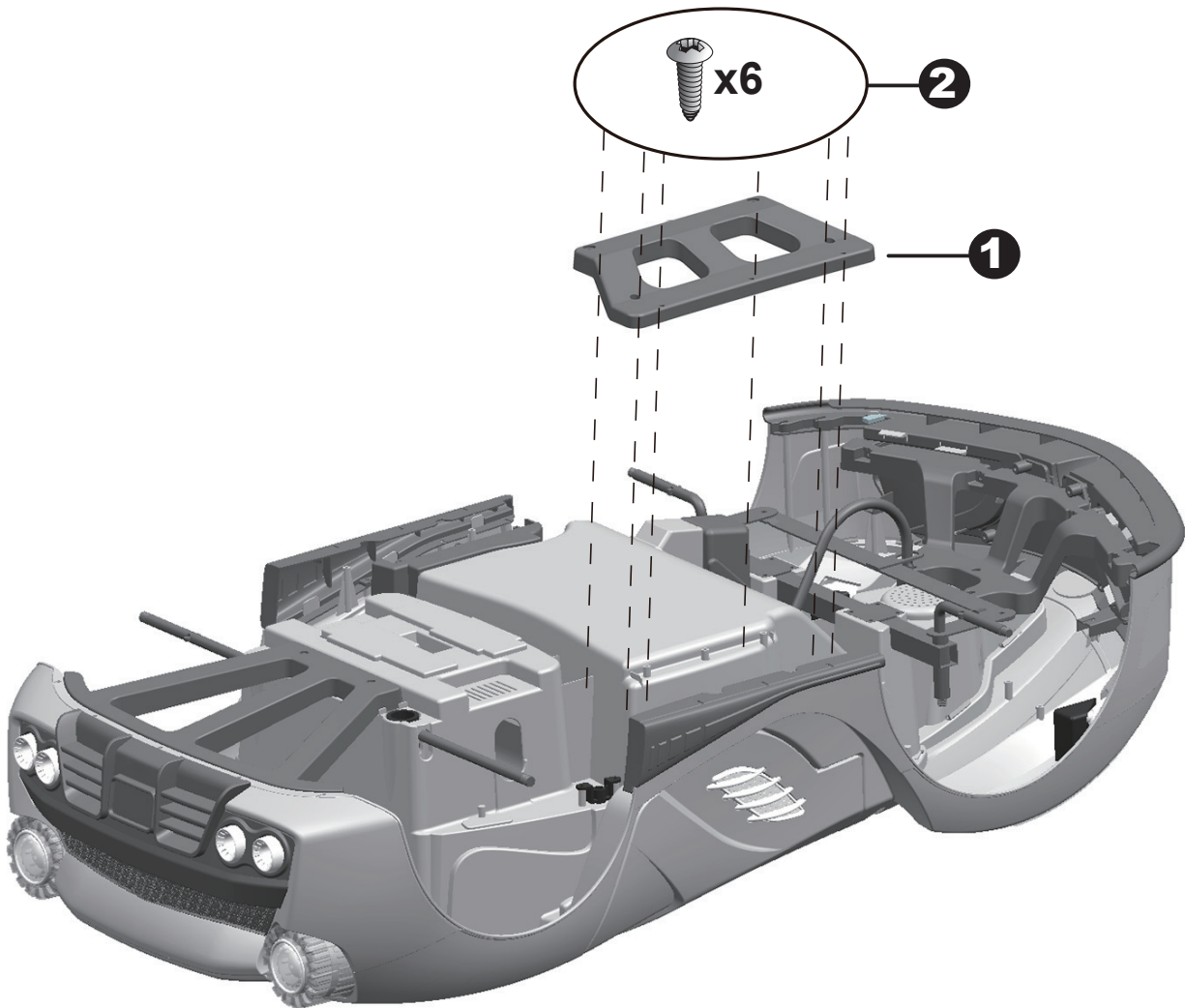

Turn the vehicle body downside up.

1. Fit the front axle to the vehicle body
2. Using 8 Ø4x12 screw to secure it to the vehicle body with a screwdriver.

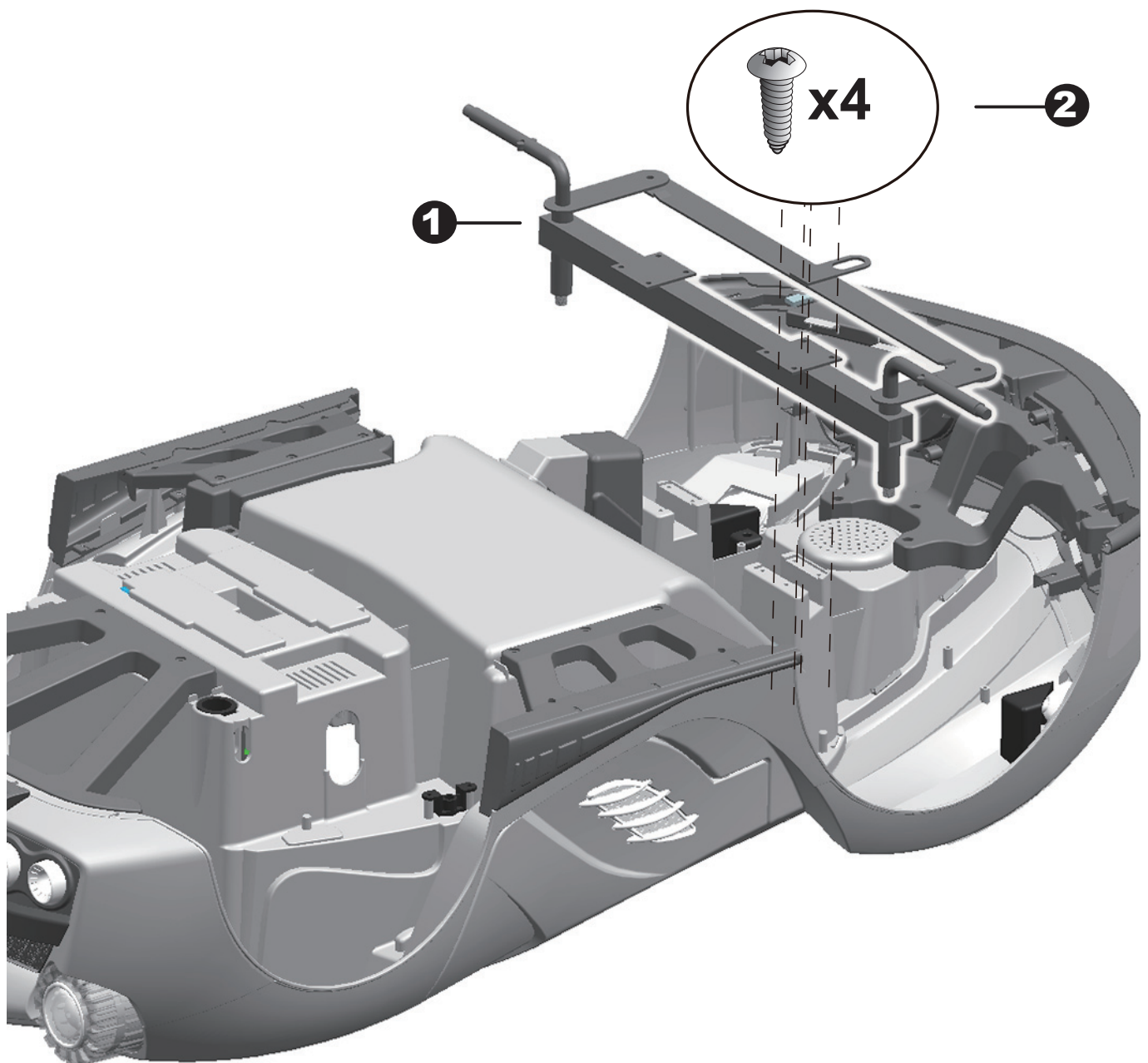

1WD

Remove all the parts from the **rear axle**.

1. Slide a **Ø10 washer** onto the rear axle from the longer end.
2. Insert the **rear axle with a Ø10 washer** into the hole in the vehicle body from **right hand side**.

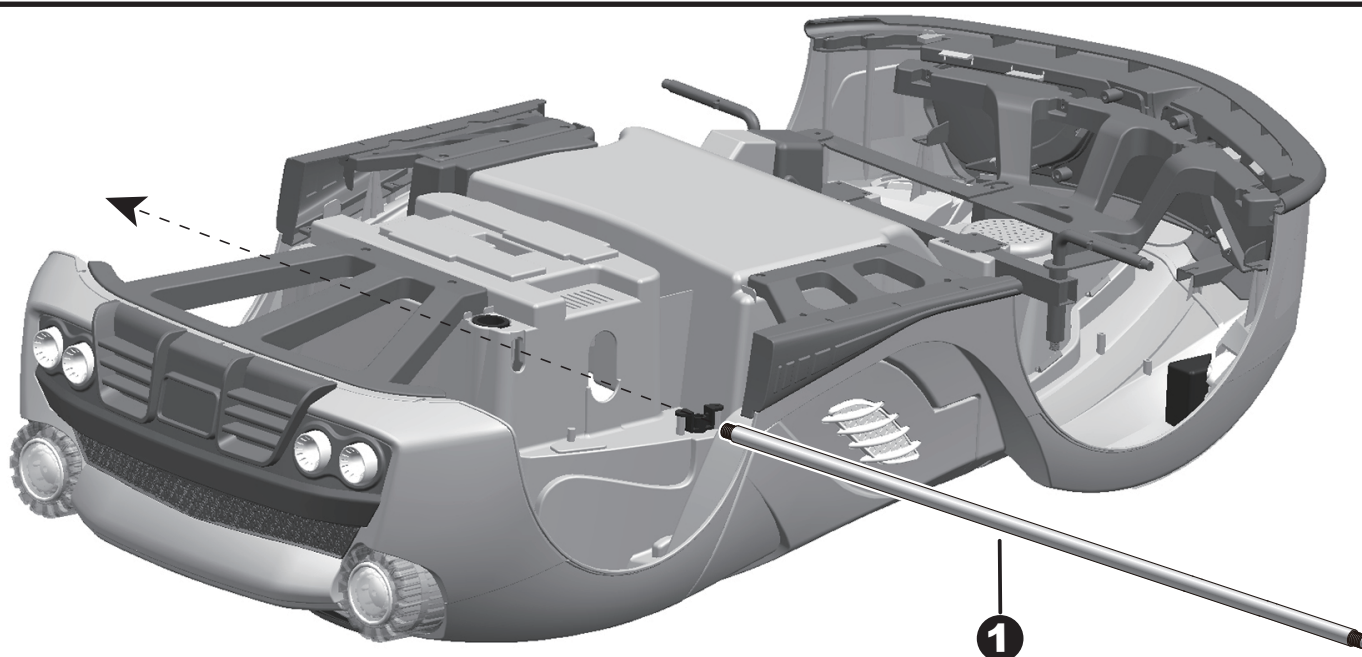
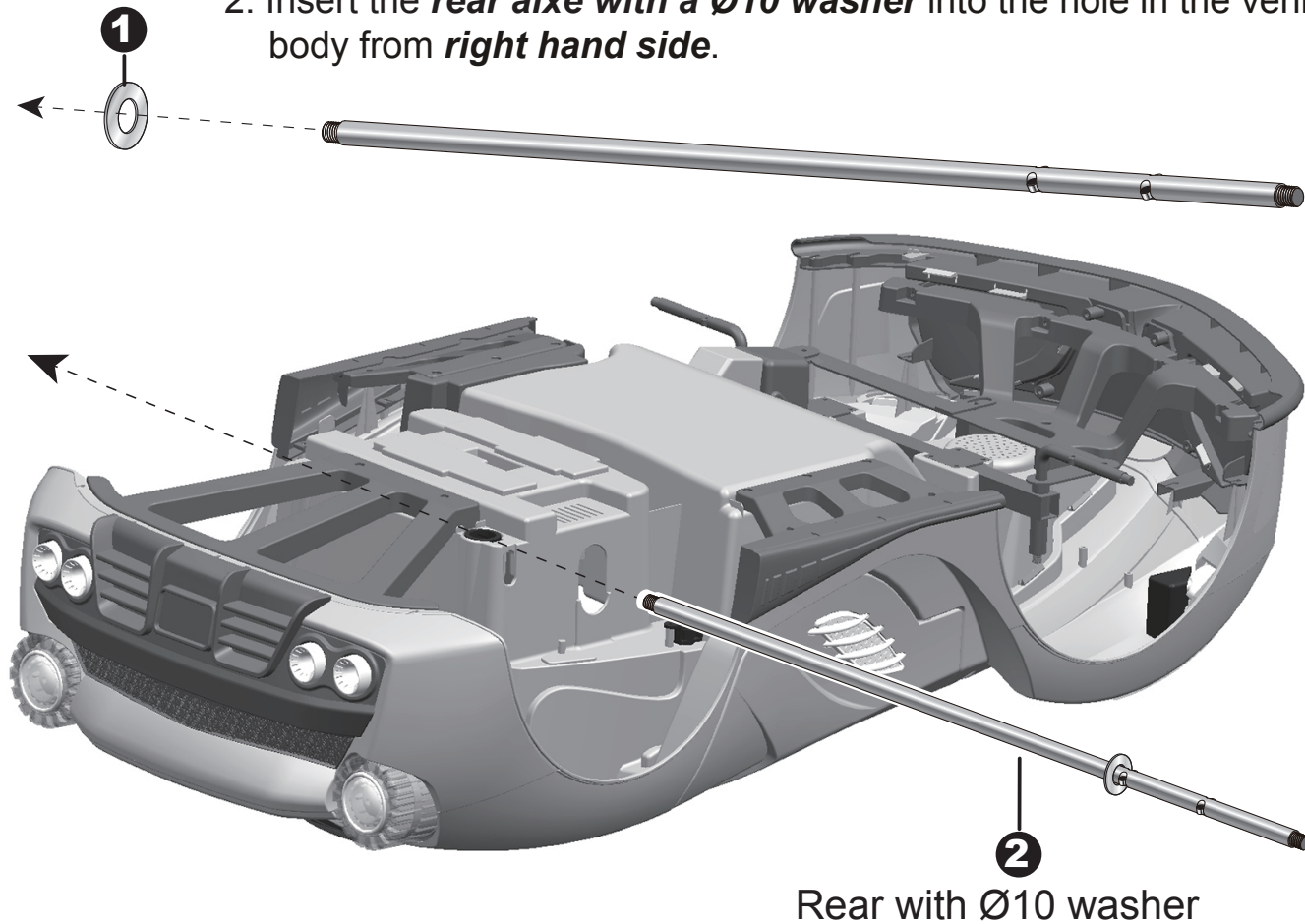

2WD

Remove all the parts from the **rear axle**.

1. Insert the rear axle into the hole in the vehicle body.

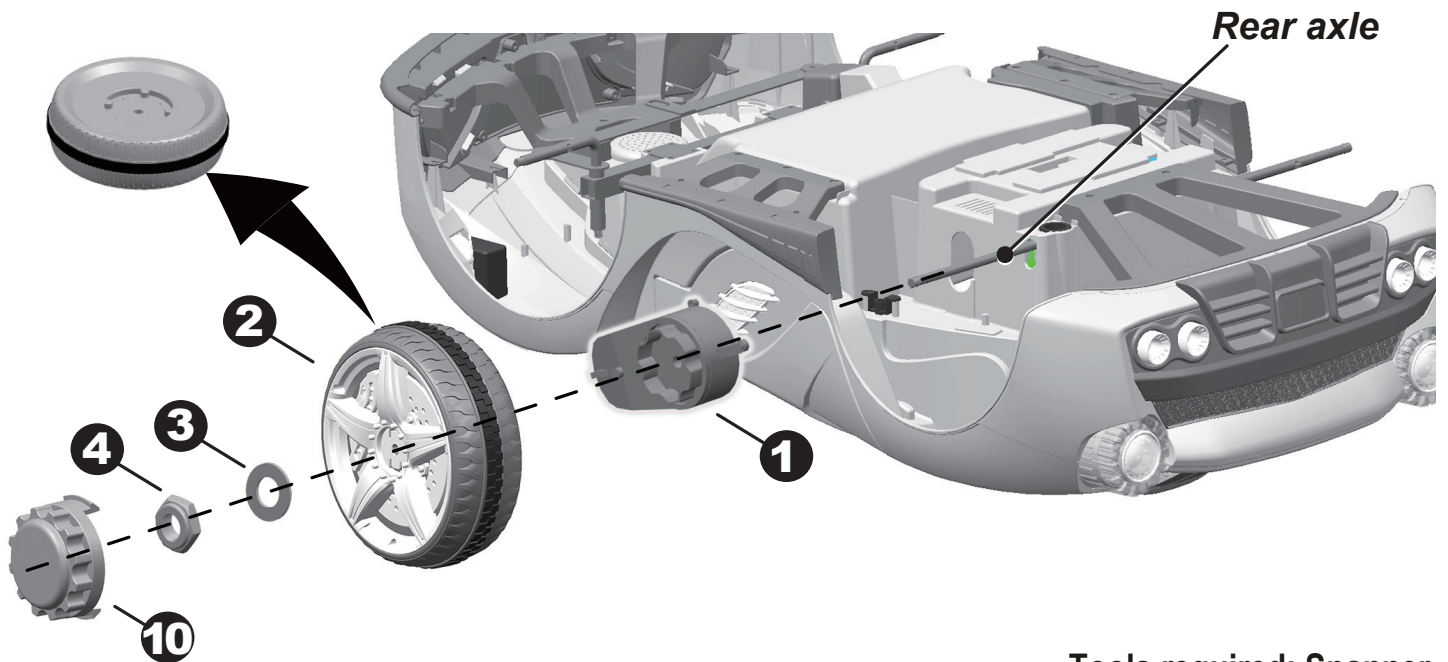

1. Slide the **gear box** onto the **rear axle (Left Side)**. Tools required: Spanner
2. Slide the **driving wheel** onto the rear axle. And keep the **driving wheel** match with the **gear box**.
3. Slide the **Ø10 Washer** onto the **rear axle**.
4. Tight a **Ø10 Locknut** to the end of the **rear axle** with a spanner.

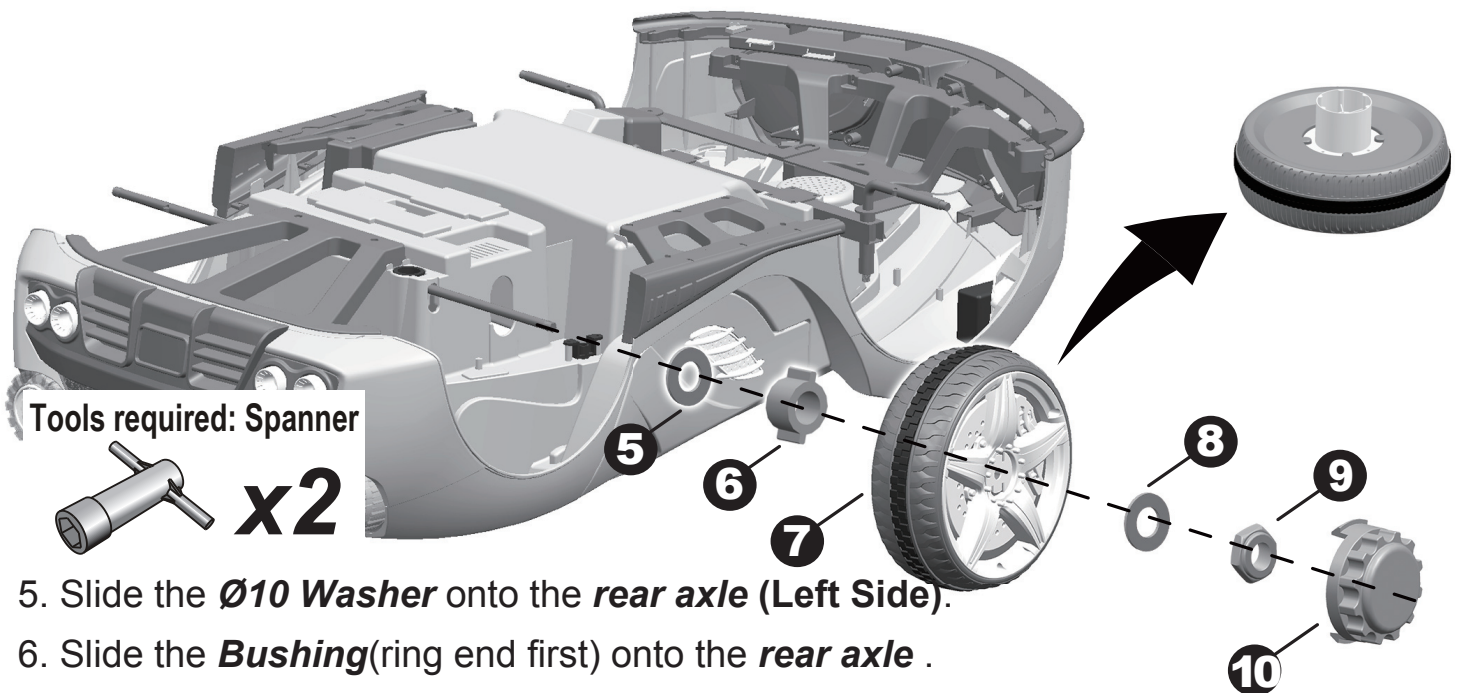

5. Slide the **Ø10 Washer** onto the **rear axle (Left Side)**.
6. Slide the **Bushing**(ring end first) onto the **rear axle** .
7. Slide the **Normal wheel** onto the rear axle. And keep it match with the **Bushing**.
8. Slide the **Ø10 Washer** onto the **rear axle**.
9. Tight a **Ø10 Locknut** to the end of the **rear axle** with a spanner. **HINT: An extra spanner has been provided to hold the Ø10 locknut on the other side of the rear axle while tightening the locknut on the other side.**
10. Fit the **hubcap** to the wheel cover.

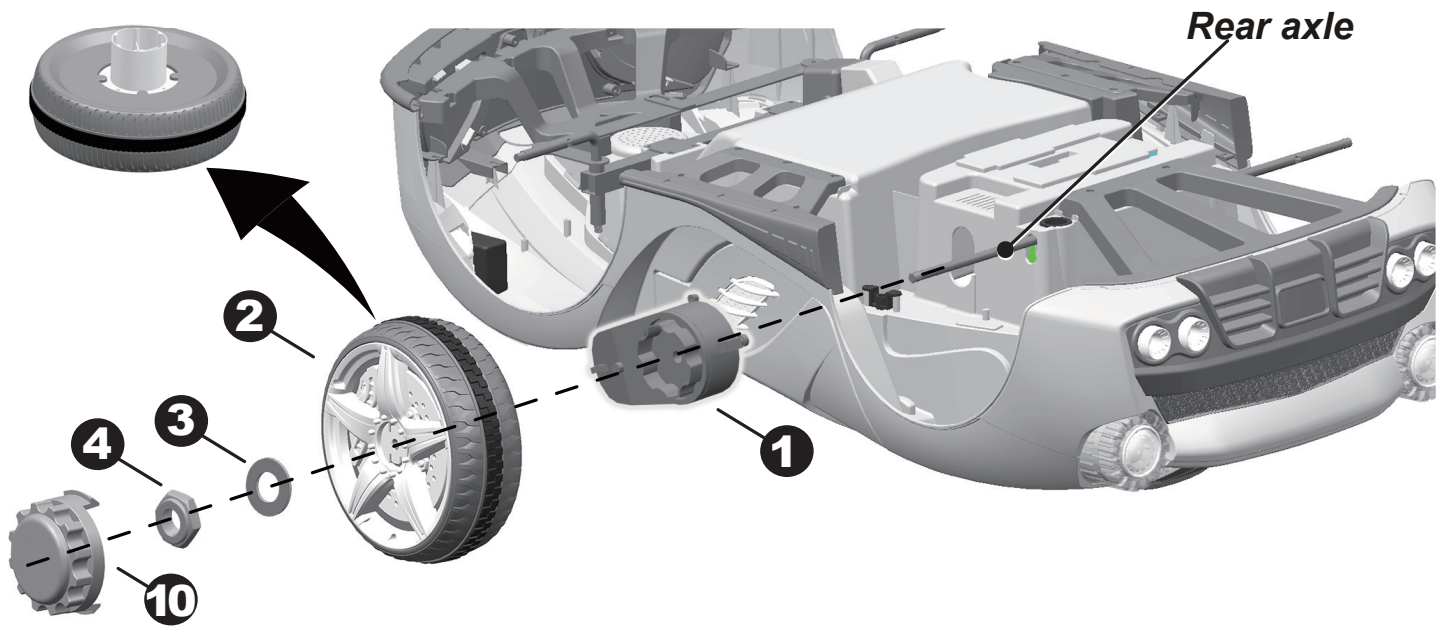

1. Slide the **gear box** onto the **rear axle (Left Side)**. "R" labeled gear box should be fit to the "R" side of vehicle body; "L" labeled gear box should be fit to "L" side of vehicle body.
2. Slide the **driving wheel** onto the rear axle. And keep the **driving wheel** match with the **gear box**.
3. Slide the **Ø10 Washer** onto the **rear axle**.
4. Tight a **Ø10 Locknut** to the end of the **rear axle** with a spanner.

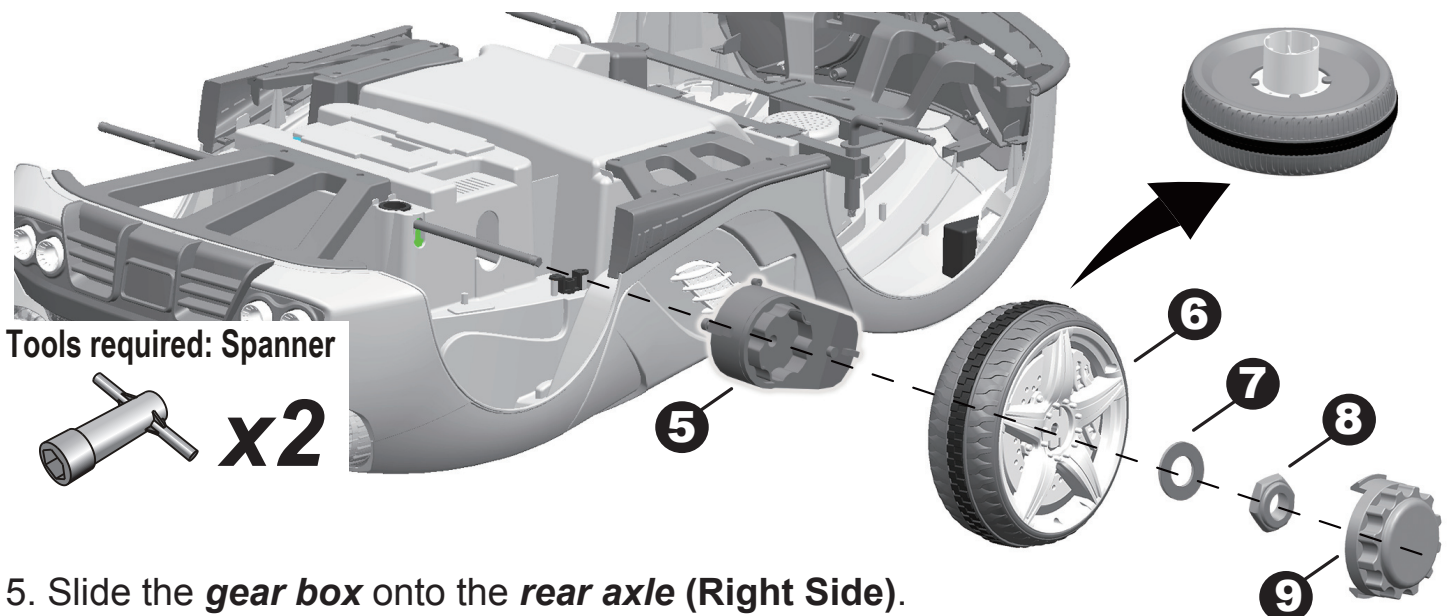

Tools required: Spanner

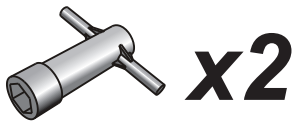

5. Slide the **gear box** onto the **rear axle (Right Side)**. "R" labeled gear box should be fit to the "R" side of vehicle body; "L" labeled gear box should be fit to "L" side of vehicle body.
6. Slide the **driving wheel** onto the rear axle. And keep the **driving wheel** match with the **gear box**.
7. Slide the **Ø10 Washer** onto the **rear axle**.
8. Tight a **Ø10 Locknut** to the end of the **rear axle** with a spanner. **HINT: An extra spanner has been provided to hold the Ø10 locknut on the other side of the rear axle while tightening the locknut on the other side.**
9. Fit the **hubcap** to the wheel cover.

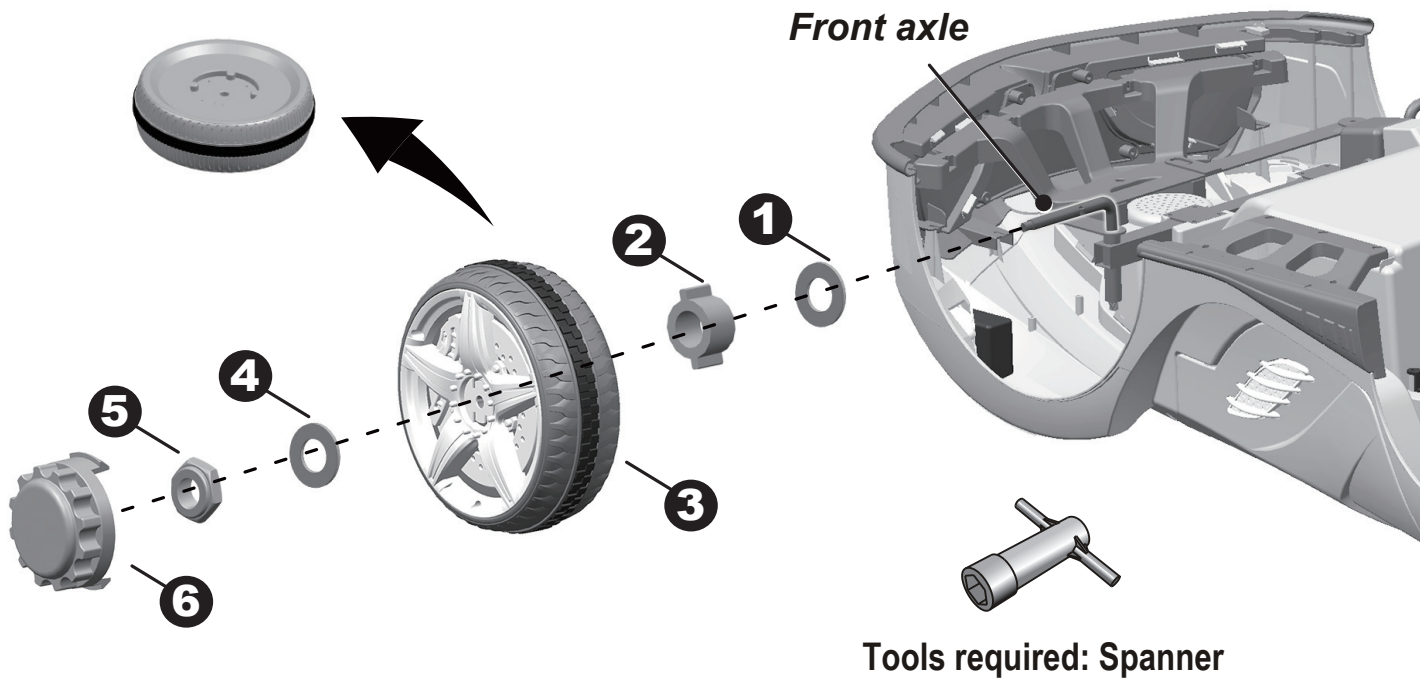

Remove all the parts from the front axle.

1. Slide a **Ø12 washer** onto the **front axle**.
2. Slide the **bushing** (ring end first) onto the **front axle**.
3. Slide the **normal wheel** (with wheel hubcap) onto the rear axle. And keep the **normal wheel** match with the **bushing**.
4. Slide a **Ø12 washer** onto the **front axle**.
5. Tight a **Ø10 Locknut** to the end of the **front axle** with a spanner.
6. “Snap” the **hubcap** to the wheel cover.

Repeat this step for the other side.

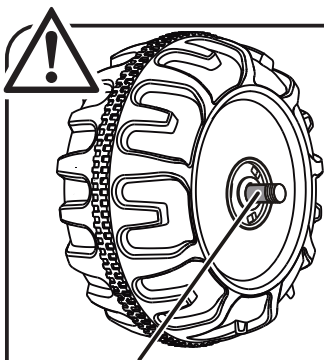

GAP

After assembling any wheel to the axles, please check the gap between the screw thread and the collapsible (refer to below picture), if the gap is too big, please add two or three washers inside the wheel, But after tightening the nut outside the wheel, please turn the wheel by your finger to check if the wheel can run smoothly, this is very important, because if the wheel can run smoothly, it is ok, but if the nut press the wheel and the wheel can't run smoothly, the motor will be broken easily! Then you need to decrease one or two washers to make sure the wheel can run smoothly!

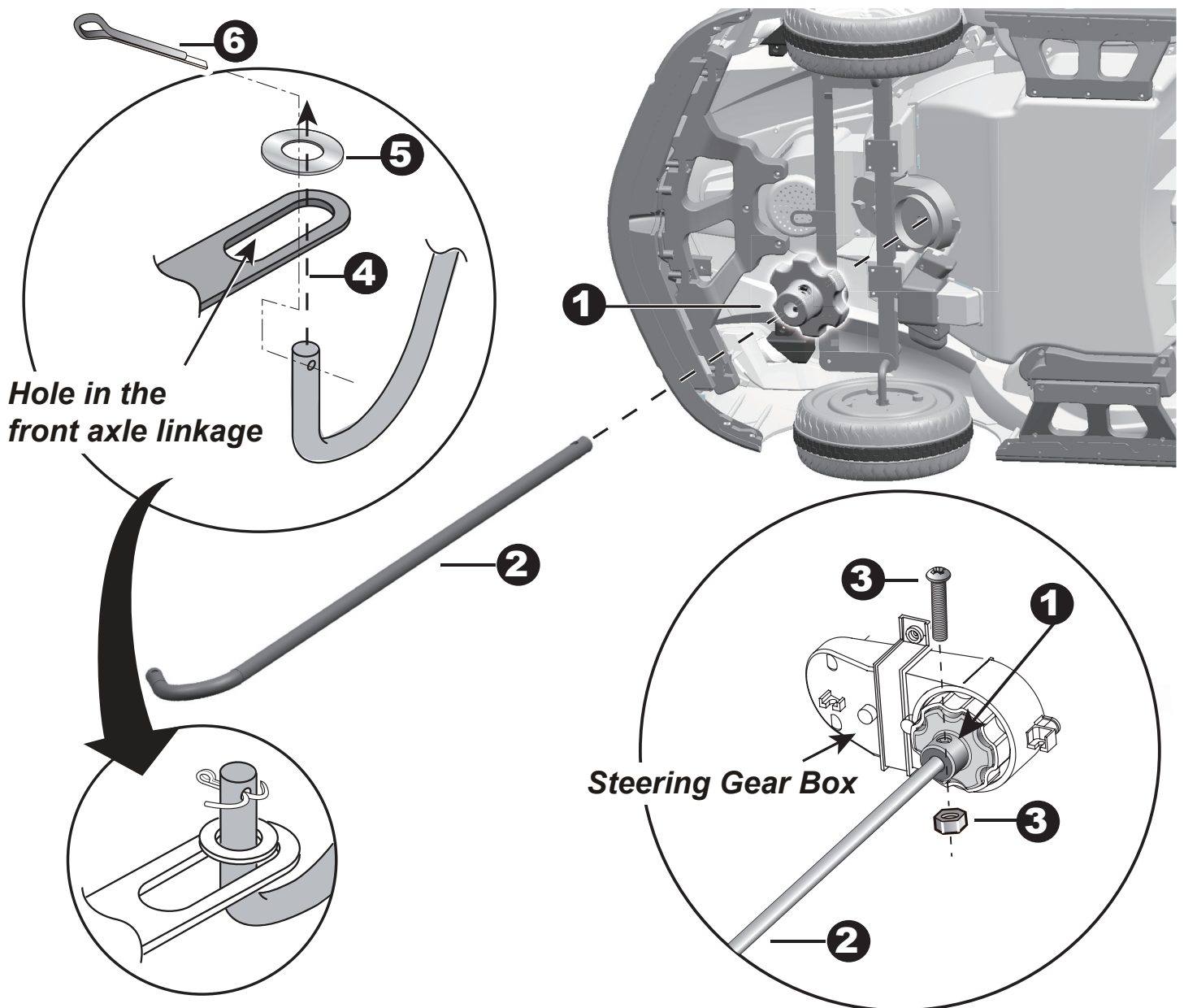

Turn the vehicle body on its side.

1. Attach the **R/C driver** to the **steering gear box**, and make it match with steering gear box.
2. Insert the **straight end of steering column** up through the **hole in the R/C driver**, **the hole in the steering gear box** from the bottom side, and out through the **hole in the dash**.
3. Line up the **holes in the R/C driver** and the **hole in the steering column**, tighten a **M5x20 machine screw** and **Ø5 nut** back in the same location with a screwdriver.
4. Insert the **bent end of steering column** through the **hole in the front axle linkage**.
5. Fit a **Ø10 washer** to the steering column.
6. Insert a **split pin** into the hole in the steering column, bend the ends of split pin back using **a long nose pliers**.

⚠ BATTERY INFORMATION

- Non-rechargeable batteries are not to be recharged.
- If removable rechargeable batteries are used, they are only to be charged under adult supervision.
- Remove rechargeable batteries from the product before charging.
- Do not mix old and new batteries. Do not mix different types of batteries: alkaline, standard (carbon-zinc) or rechargeable (nickel-cadmium).
- Insert batteries as indicated inside the battery compartment, anode to anode, cathode to cathode.
- Remove batteries during long periods of non-use. Always remove exhausted batteries from the product. Battery leakage and corrosion can damage this product. Dispose of batteries safely.
- Never short circuit the battery terminals.

Add the Batteries (NON PROVIDED) of Steering Wheel

1. With a screwdriver remove the **screw** on the **battery cover** located in the center of the steering wheel.
2. Remove the **battery cover** from the top of the **battery compartment**.
3. Insert two **AA batteries** in their correct polarities.
4. Place the **battery cover** over the **battery compartment** and fasten with the **screw** you removed in step one.

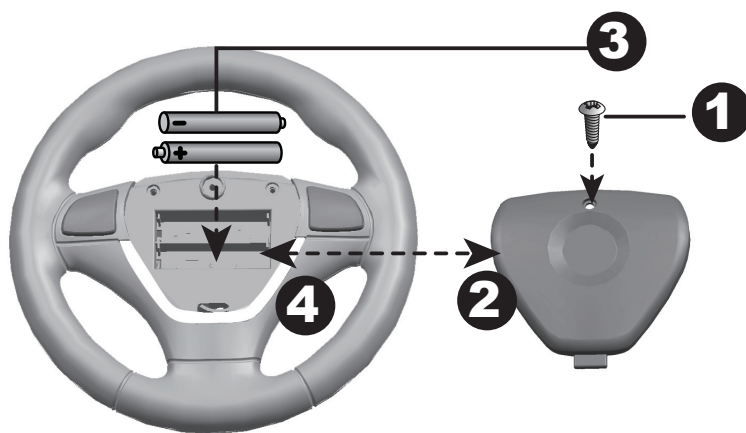

Turn the vehicle body upright. Remove the **M5x45 machine screw** and **Ø5 nut** from the **steering wheel**.

5. Place the **steering wheel** over the **steering column**, protruding from the middle of the **steering wheel base**.
6. Align the **holes** on each side of **steering wheel** with the holes at the **end of the steering column**.
7. Fasten a **nut** on the opposite end of the **screw** to secure the **steering wheel to the steering column**.

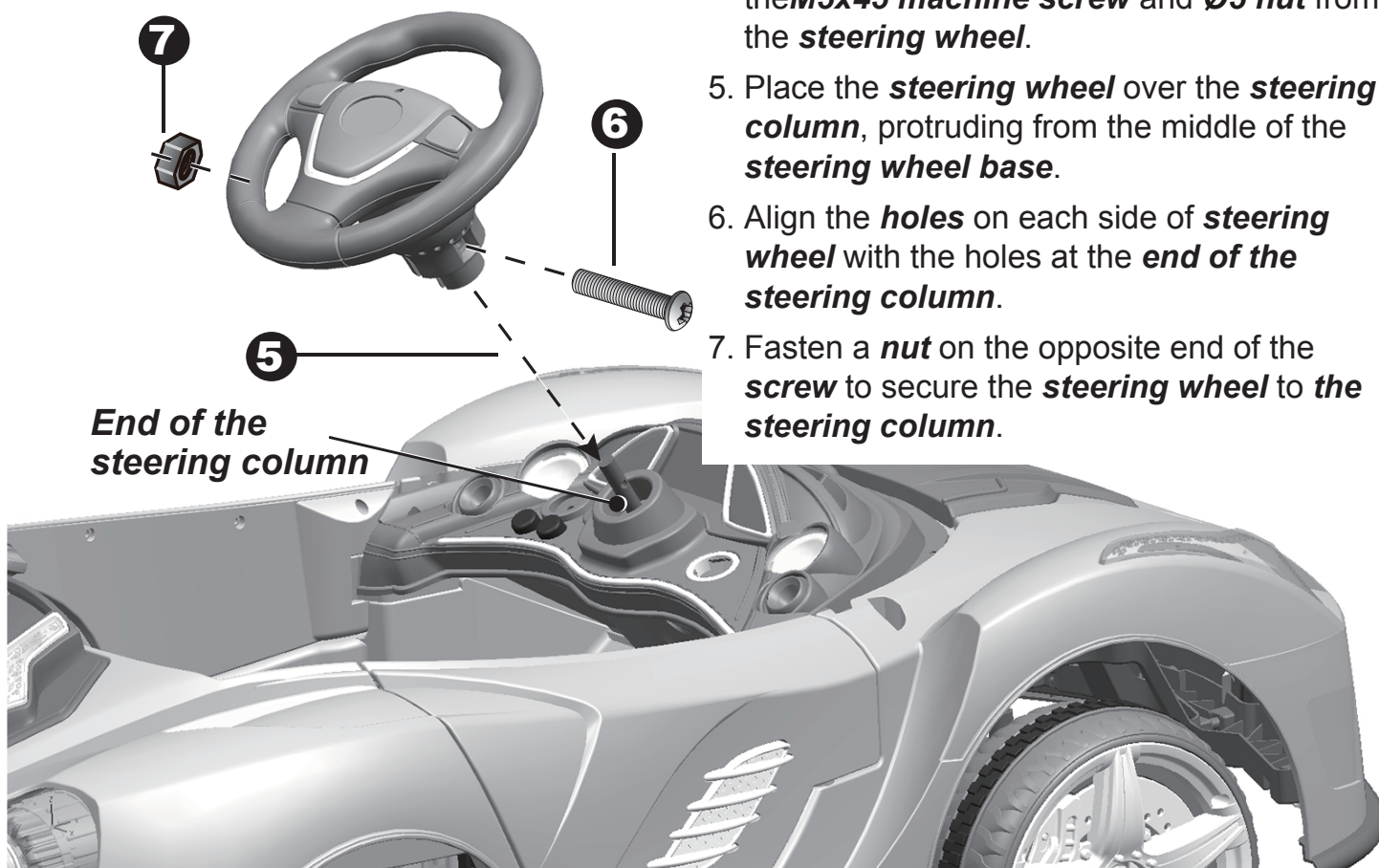

1. Insert the tabs on the windshield into the slots in the vehicle body. Push until you hear it “click” into place.
2. Using 2 Ø5x12 screws to secure it with a screwdriver.

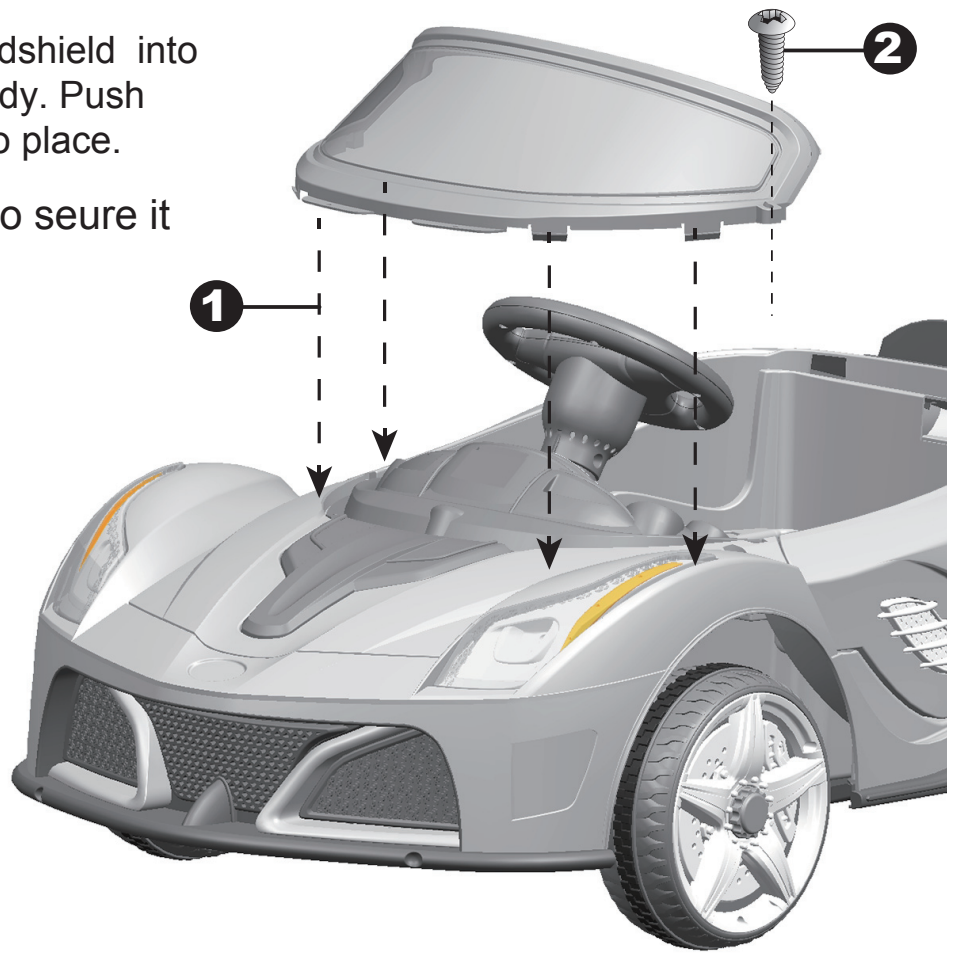

3. Insert the **view mirror** into the slots of the **rear view mirror bracket** located on the vehicle body. Repeat for the other side.

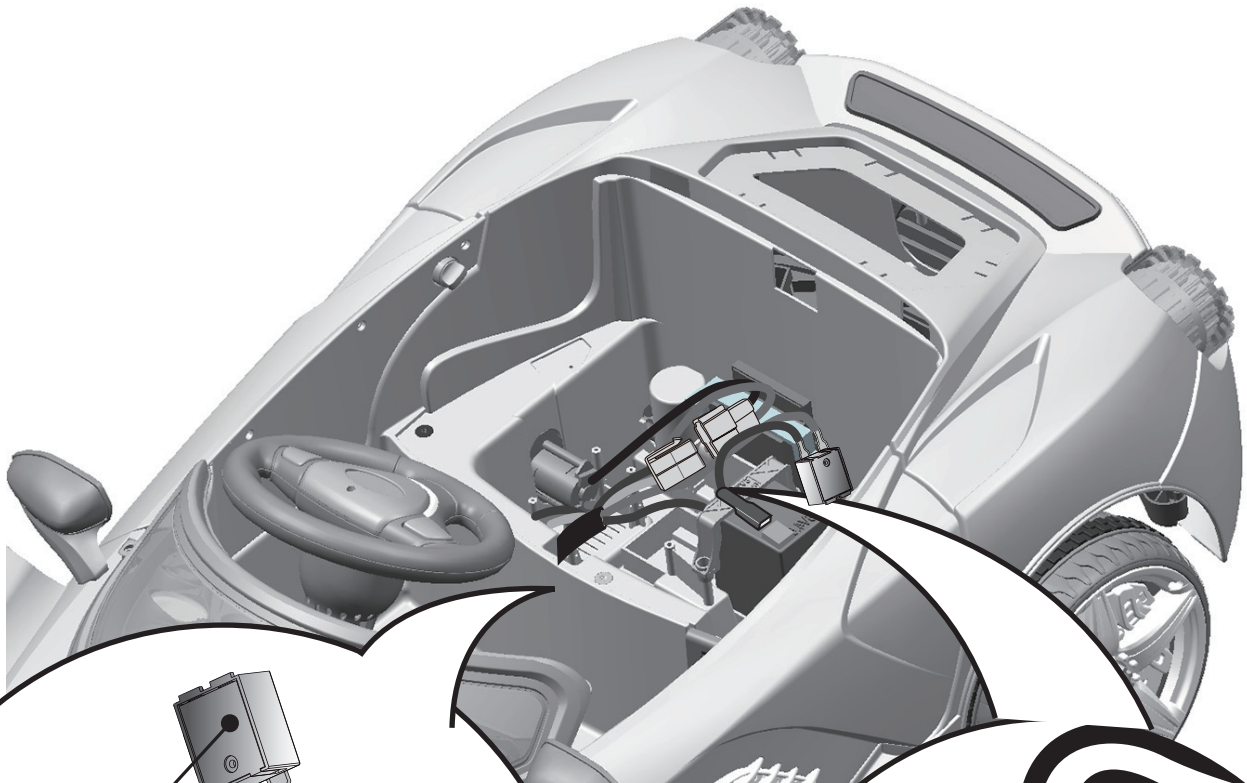

Fuse box

Battery

1

Vehicle connector

Motor connector

2

1WD

1. Plug the **Vehicle Connector** into the **Motor Connector** on body as shown above.
2. Plug the **Red fuse connector** into the **terminal on battery**.

2WD

1. Plug the **Vehicle Connector** into the **Motor Connector** on body as shown above. Repeat for the other side.
2. Plug the **Red fuse connector** into the **terminal on battery**.

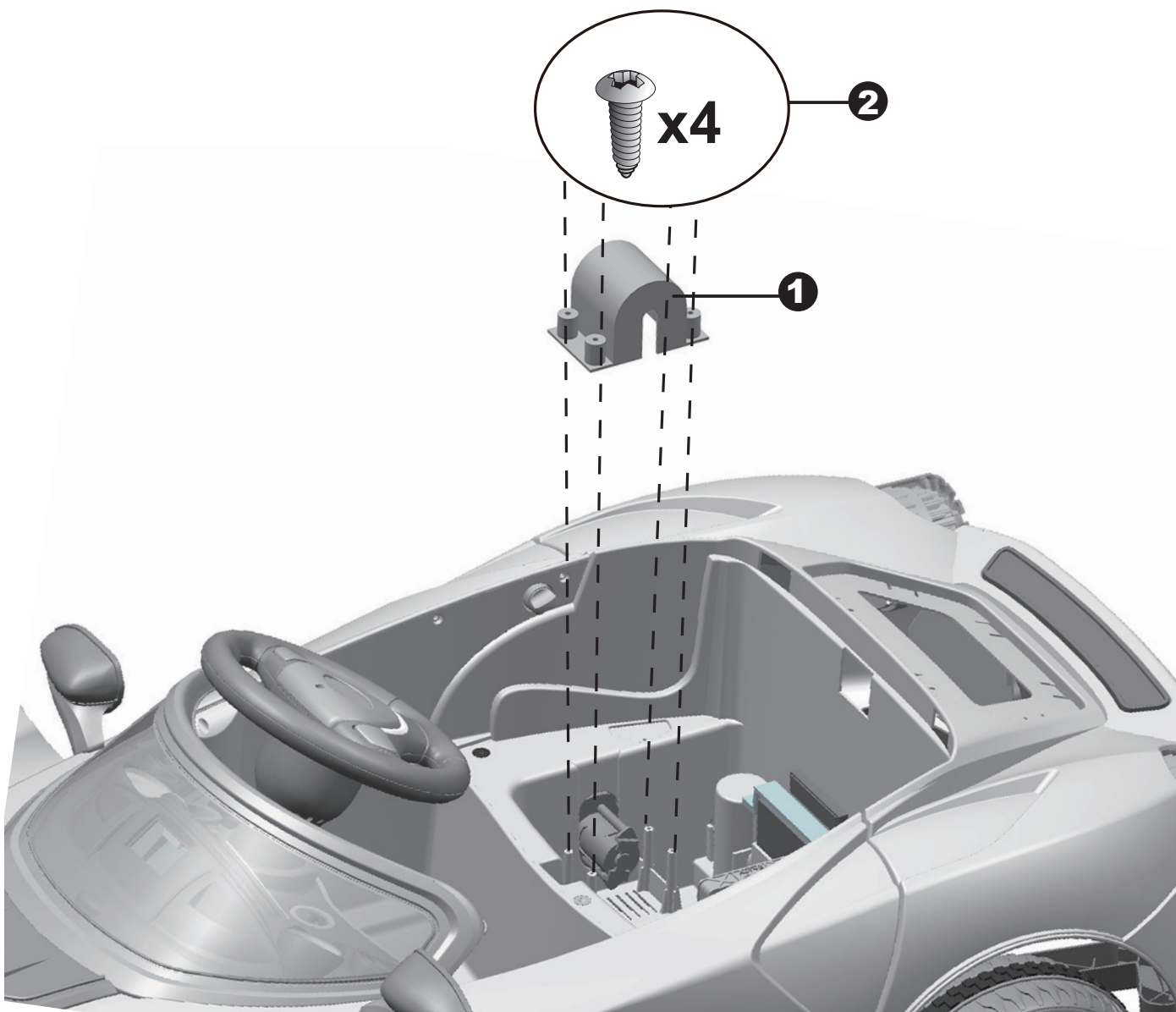

1WD

1. Fit the **motor hood** on the motor. Push until you hear it “click” into place.

2WD

1. Fit the **motor hood** on the motor. Push until you hear it “click” into place.
Repeat the above step for the other **Motor hood**.

1. Fit the **tabs at back of the seat** to the **holes in the vehicle body**.
2. Tighten two **M5x12 machine screws** with a screwdriver.

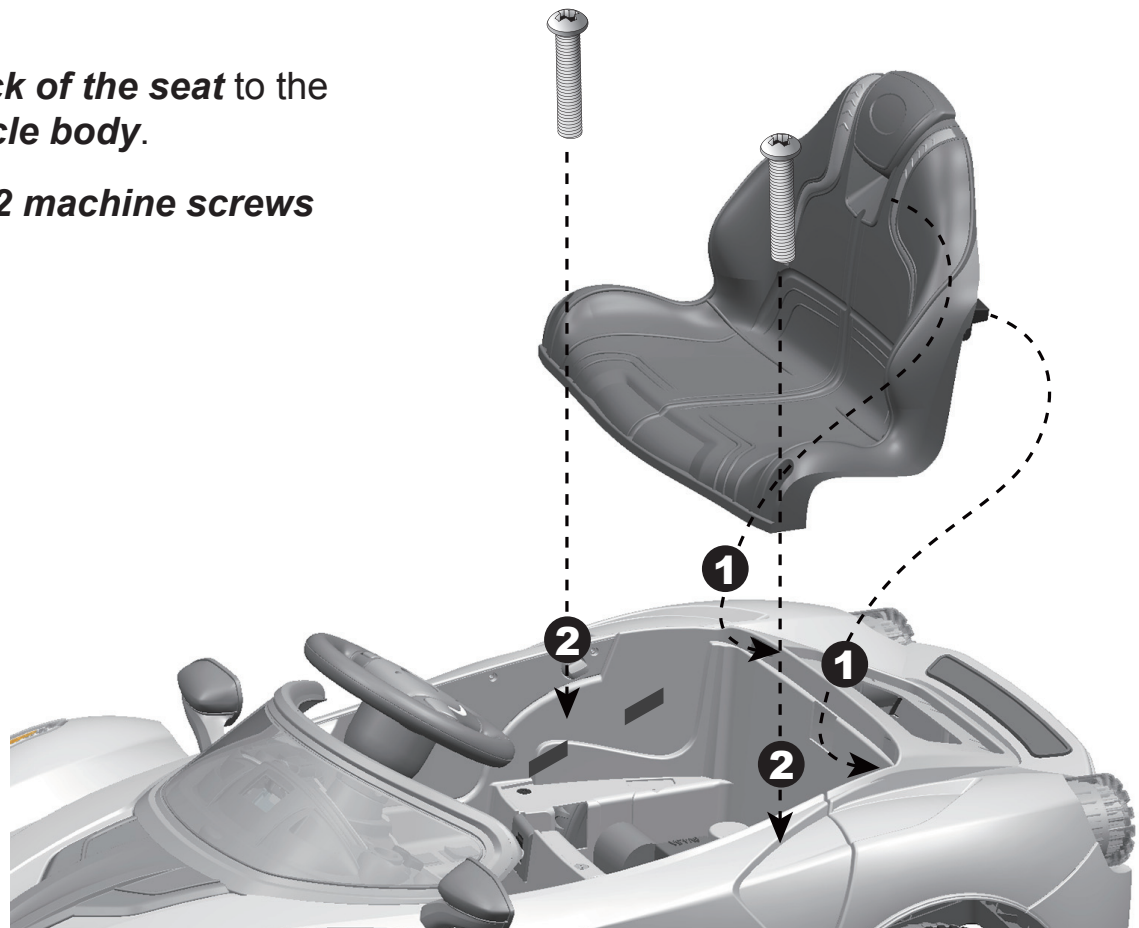

3. Insert the tabs on the engine into the slots in the vehicle body, and push until you hear it “click” into place.

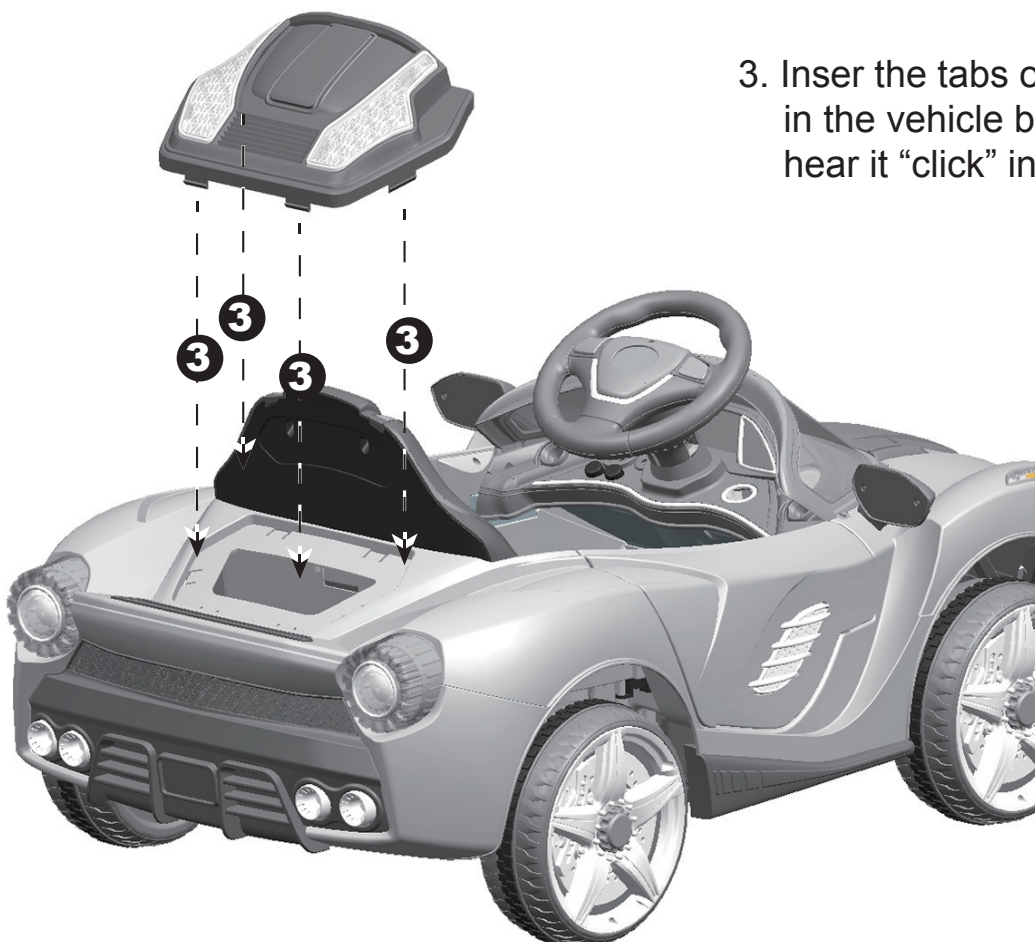



WARNING!

PREVENT INJURIES AND DEATHS:

- **NEVER LEAVE CHILD UNATTENDED. ADULT DIRECT SUPERVISION IS REQUIRED.**
Always keep child in view when child is in vehicle.
- This toy should be used with caution since skill is required to avoid falls or collisions causing injury to the user or third parties.
- Protective equipment should be worn.
- Never use in roadways, near cars, on or near steep inclines or steps, swimming pools or other bodies of water.
- Always wear shoes.
- Always sit on the seat.
- Not to be used in traffic.
- This toy is unsuitable for children under 37 months due to its maximum speed; Maximum user weight is 30 kgs.
- This toy has no brake.

Must confirm before using that following work which is already finished:

- **Important!** Before using the vehicle for the first time, the battery needs to be charged for 4 to 6 hours, no more than 10 hours. Only an adult can charge and recharge the battery.
- Check all the screws, cap nuts and protective coverings regularly and tighten as required.

Rules for Safe Riding

- Keep Children within Safe Riding Areas:
 - Never use in roadway, near motor vehicles, on lawn space, on or near steep inclines or steps, swimming pools or other bodies of water;
- Use the toy only on flat surfaces. Such as inside your house, garden or playground.
- Never use in the dark. A child could encounter unexpected obstacles and have an accident. Operate the vehicle only in the daytime or a well-lit area.
- It is prohibited to change the circuit or add other electric parts
- Inspect wires and connections of the vehicle periodically.
- Do not let any child touch the wheels or be near them when the car is moving .
- This vehicle has adjustable play seat belts. Please instruct children how to tie the safety belt before using, guarantee the security.



Use the vehicle on generally level ground ONLY!

DO NOT Use the vehicle on Lawn space!

**IMPORTANT!**

Always stop vehicle when changing the speed or direction to avoid damage the gears and motor.

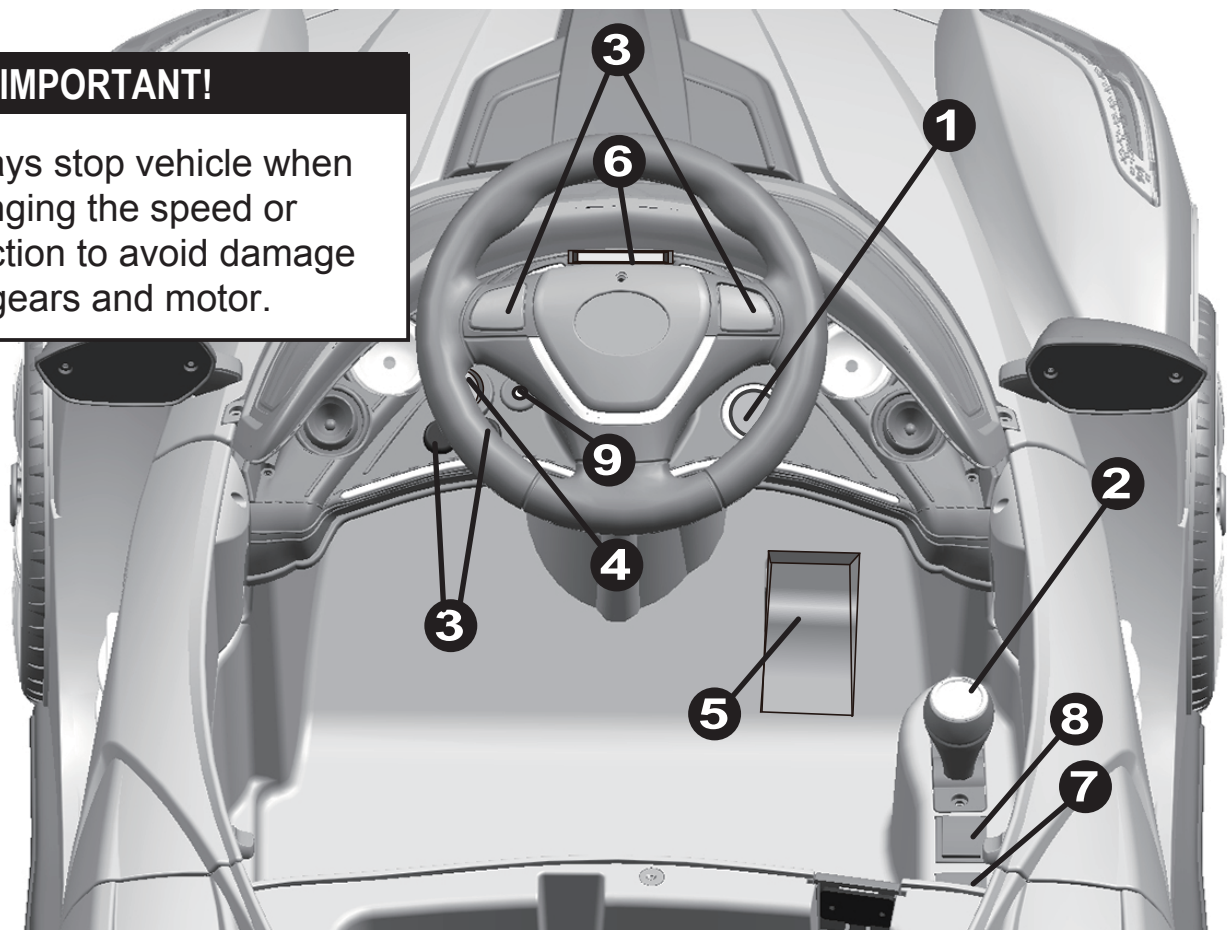

1. **Power Switch:** Turns the vehicle on and off.
2. **Shift Lever:** Changes the direction that vehicle moves from forward to reverse.
 - To move the car forward, shift the lever up
 - To move the car backward, shift the lever down.
 - Shift the lever in the middle, the stop.
3. **Sounds buttons:** Press for sounds playing.
4. **Volume knob (OPTIONAL):** Turn the knob clockwise to increase the volume; Turn the knob counterclockwise to decrease the volume.
5. **Foot pedal:** Applies power (speed) to the vehicle.
 - To move the car, press the pedal down.
 - To brake or slow down, release pressure from the pedal.
6. **Digital voltmeter (OPTIONAL):** See <Charging>, page 21.
7. **Foot - R/C switch (OPTIONAL):** Change the operating mode, foot-operate or R/C-operate.
8. **High/Low speed switch (OPTIONAL):** The switch operates the vehicle to move in low or high speed.
9. **3.5 mm Audio input connector (OPTIONAL)**

**ADVANCED USE - High speed Drive**

Make sure your child knows how to steer, how to start and stop the vehicle and knows the rules for safe driving. The vehicle can be driven at a maximum of 3~5 km/h.

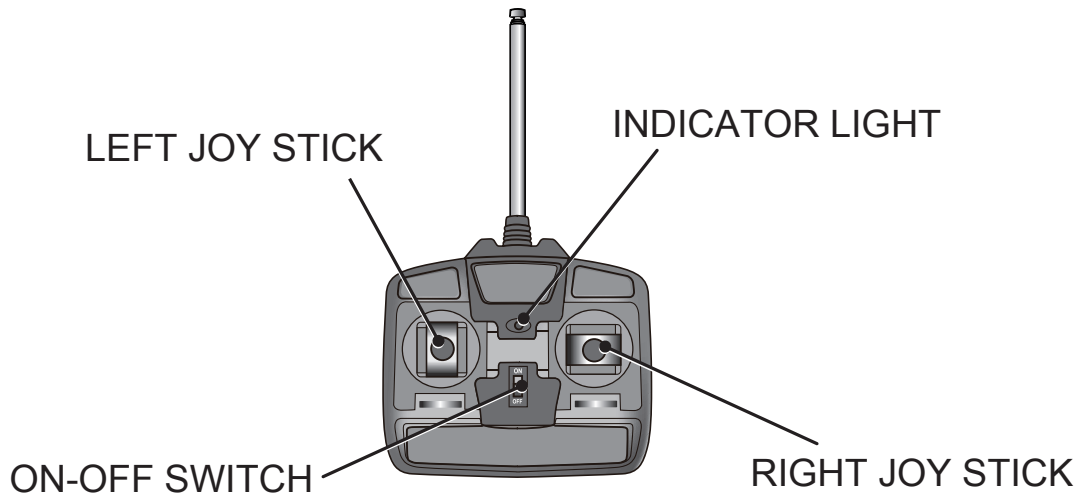
ADULT OPERATING REQUIRED**ASSEMBLY**

1. Insert the antenna into the controller by tweak the antenna clockwise;
2. Lift the battery compartment door on the back of the controller and insert two AA(LR6) batteries.

NOTE: This product does not include the AA(LR6) batteries.

OPERATION

1. Press the FOOT - R/C SWITCH on the vehicle to the “Remote control” position.
2. Press the ON-OFF SWITCH on the remote controller to the “ON” position, the indicator light will be lighting.
3. Push the LEFT JOY STICK to the front, the vehicle goes forward, pull the LEFT JOY STICK to the back, the vehicle goes backward.
4. Push the RIGHT JOY STICK to the left, the vehicle turn left, push the RIGHT JOY STICK to the right, the vehicle turns right.

**BATTERY INFORMATION**

- DO NOT mix old and new batteries.
- DO NOT mix alkaline, standard (carbon-zinc) or rechargeable batteries.
- DO NOT charge non-rechargeable batteries. Always have adult supervision when charging rechargeable batteries.

ONLY AN ADULT CAN CHARGE AND RECHARGE THE BATTERY!



WARNING!

- **PREVENT FIRE AND ELECTRIC SHOCK:**

- Use the only rechargeable battery and charger supplied with your vehicle. NEVER substitute the battery or the charger with another brand. Using another battery or charger may cause a fire or explosion.
- Do not use the battery or charger for any other product. Overheating, fire or explosion could occur.
- NEVER modify the electric circuit system. Tampering with the electric system may cause a shock, fire or explosion or may permanently damage the system.
- Do not allow direct contact between battery terminals. Fire or explosion can occur.
- Do not allow any type of liquid on the battery or its components.
- Explosive gasses are created during charging. Do not charge near heat or flammable materials. Charge the battery in a well-ventilated area ONLY.
- NEVER pick up the battery by the wires or charger. Damage can occur to the battery and may cause a fire. Pick up the battery by the case ONLY.
- Charge the battery in a dry area ONLY.
- Battery posts, terminals and related accessories contain lead and lead compounds, chemicals known to the State of California to cause cancer and reproductive harm. **Wash hands after handling.**
- Do not open the battery. Battery contains lead acid and other materials that are toxic and corrosive.
- Do not open the charger. Exposed wiring and circuitry inside case may cause electric shock. Only adults may handle or charge the battery. NEVER allow child to handle or charge the battery. Battery is heavy and contains lead acid (electrolyte).
- Do not drop the battery. Permanent damage to the battery could occur or cause serious injury.
- Before charging the battery, check for wear or damage to the battery, charger, its supply cord and the connectors. DO NOT charge the battery if any damage to parts has occurred.
- Do not allow the battery to drain completely. Recharge the battery after each use or once a month if not used regularly.
- Do not charge battery upside down.
- Always secure the battery with the bracket. Battery can fall out and injure a child if vehicle tips over.

- The charging input socket is ***under the seat***.
- The POWER SWITCH must be turned in **OFF** position when charging.
- Before the first use, you should charge the battery for 4-6 hours. Do not recharge the battery for more than 10 hours to avoid overheating the charger.
- When the vehicle begins to run slowly, recharge the battery.
- After each use or once a month minimum recharge time as 8 to 12 hours, less than 20 hours at most.

- If your ride-on with a **Digital voltmeter(OPTIONAL)**, the magnitude of voltage will tell you how much power is remaining in the battery when you must recharge the battery. Make sure the vehicle is stop!

BATTERY	MAGNITUDE OF VOLTAGE	BATTERY STATE
6V4Ahx1, 6V7Ahx1 6V10Ahx1	≥ 6.6	The battery is full.
	6.5~6.3	The vehicle can work normally.
	≤ 6.2	STOP operating the vehicle, the battery needs to be charge.
6V4Ahx2, 6V7Ahx2, 6V10Ahx2, 12V7Ahx1, 12V10Ahx1	≥ 13.2	The battery is full.
	13.1~12.6	The vehicle can work normally.
	≤ 12.5	STOP operating the vehicle, the battery needs to be charge.

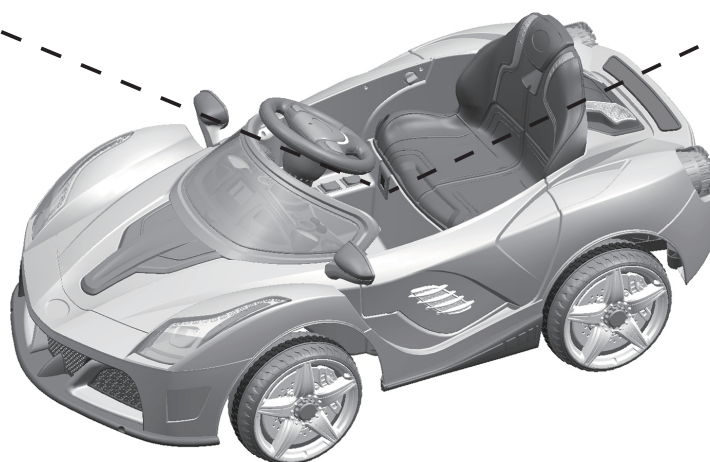
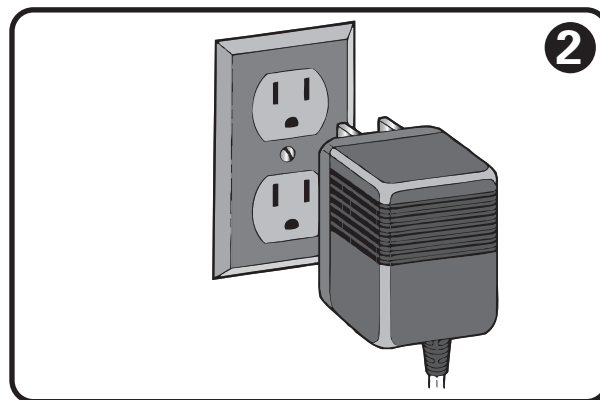
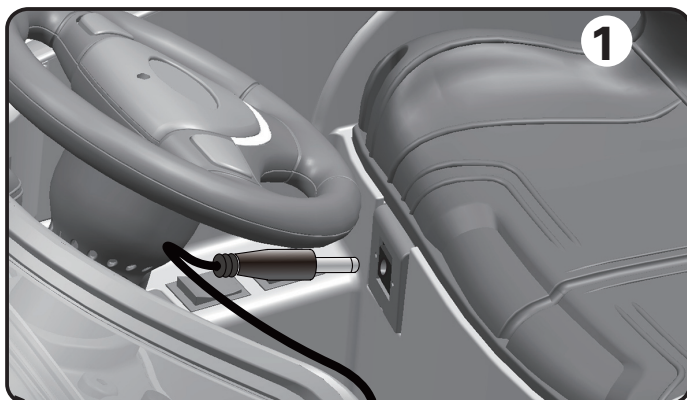

1. Plug the charger port into the input socket. (the socket is under the seat)
2. Plug the charger plug into a wall outlet. The battery will begin charging.



WARNING!

This product has CHARGING PROTECTION: When charging, all the functions will be cut off!

The battery features a thermal fuse with a reset fuse that will automatically trip and cut all power to the vehicle if the motor, electric system or battery is overloaded. The fuse will reset and power will be restored after the unit is turned OFF for five Minutes and then turned ON again. If the thermal fuse trips repeatedly during normal use, the vehicle may need repair. **Contact your distributor please.**

To avoid losing power, follow these guidelines:

- Do not overload the vehicle.
- Do not tow anything behind the vehicle.
- Do not drive up steep slopes.
- Do not drive into fixed objects, which may cause the wheels to spin, causing the motor to overheat.
- Do not drive in very hot weather, components may overheat.
- Do not allow water or other liquids to come in contact with the battery or other electric components.
- Do not tamper with the electric system. Doing so may create a short, causing the fuse to trip.

Battery Replacement and Disposal



The battery will eventually lose the ability to hold a charge. Depending on the amount of use, and varying conditions, the battery should operate for one to three years. Follow these steps to replace and dispose the battery:

1. Remove the car seat.
2. Disconnect the battery connectors.
3. Remove the battery bracket.
4. Remove the battery cover.
5. Carefully lift the battery.
 - Depending on the condition of the battery (i.e.: leakage) you may want to wear protective gloves before removal.
 - Do not lift the battery by its connectors or cables.
6. Place the dead battery in a plastic bag.

Important! Recycle the dead battery responsibly. The battery contains lead acid (electrolyte) and must be disposed of properly and legally. It is illegal in most areas to incinerate lead acid batteries or dispose of them in landfills. Take it to a federal or state-approved lead acid battery recycler, such as local automotive battery retailer.

Do not throw the battery away with your regular household waste!

7. Replace the battery and reconnect the connectors.
8. Replace the metal battery bracket.
9. Replace the seat.

Problem	Possible Cause	Solution
Vehicle dose not run	Battery low on power	Recharge battery.
	Thermal fuse has tripped	Reset fuse, see <Fuse>
	Battery connector or wires are loose	Check if the battery connectors are firmly plugged into each other. If wires are loose around the motor contact your distributor please.
	Battery is dead	Replace battery, contact your distributor please.
	Electrical system is damaged	Contact your distributor please.
	Motor is damaged	Contact your distributor please.
Vehicle dose not run very long	Battery is under charged	Check if the battery connectors are firmly plugged into each other when recharging
	Battery is old	Replace battery, contact your distributor please.
Vehicle runs sluggishly	Battery low on power	Recharge battery, contact your distributor please.
	Battery is old	Replace battery, contact your distributor please.
	Vehicle is overload	Reduce weight on vehicle. Maximum user weight is 30 kgs.
	Vehicle is being used in harsh conditions	Avoid using vehicle in harsh conditions ,see <Safety>.
Vehicle needs a push to go forward	Poor contact of wires or connectors	Check if the battery connectors are firmly plugged into each other. If wires are loose around the motor, contact your distributor please.
	“Dead Spot” on motor	A dead spot means the electric power is not being delivered to the terminal connection and the vehicle needs repair. Contact your distributor please.
Difficult shifting from forward to reverse or vice-versa	Attempting to shift while the vehicle is moving	Completely stop the vehicle and shift, see <Use Your Ride-On>
Loud grinding or clicking noises coming from motor or gear box	Motor or gears are damaged	Contact your distributor please.
Battery will not recharge	Battery connector or adapter connector is loose	Check if the battery connectors are firmly plugged into each other.
	Charger not plugged in	Check if the battery charger is plugged into a working wall outlet.
	Charger is not working	Contact your distributor please.
Charger feels warm when recharging	This is normal and not a cause for concern	

Completely read through this manual and the troubleshooting guide table before calling. If you still need help resolving the problem **Contact your distributor please.**

- It is parents' responsibility to check main parts of the toy before using, Must regularly examine for potential hazard, such as the battery, charge, cable or cord, plug, screws are fastening enclosure of other parts and that in the event of such damage, the toy must not be until that damage had been properly removed.
- Make sure the plastic parts of the vehicle are not cracked or broken.
- Occasionally use a lightweight oil to lubricate moving parts such as wheels.
- Park the vehicle indoors or cover it with a tarp to protect it from wet weather.
- Keep the vehicle away from sources of heat, such as stoves and heaters. Plastic parts may melt.
- Recharge the battery after each use. Only an adult can handle the battery. Recharge the battery at least once a month when the vehicle Raider is not being used.
- Do not wash the vehicle with a hose. Do not wash the vehicle with soap and water. Do not drive the vehicle in rainy or snowy weather. Water will damage the motor, electric system and battery.
- Clean the vehicle with a soft, dry cloth. To restore shine to plastic parts, use a non-wax furniture polish. Do not use car wax. Do not use abrasive cleaners.
- Do not drive the vehicle in loose dirt, sand or fine gravel which could damage moving parts, motors or the electric system.
- When not using, all the electrical source should be turn off. Turn off the power switch and disconnect the battery connection.

Our products are suitable for

ASTM F963; GB6675; EN71 and ***EN62115*** standard.