

# OPERATION MANUAL

## ZP5388

Remote control

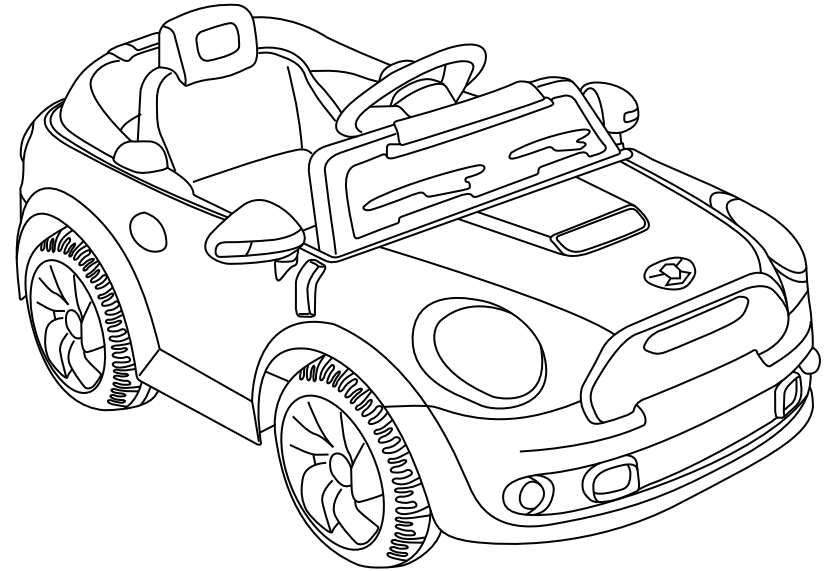

Our products are suitable for the following standard:

- GB6675,GB19865
- ASTM-F963,CPSIA
- EN71 AND EN62115

## 11. Care and maintenance

- (1). Adults should check regularly (once every two weeks suggested), wires, plugs, electrical, housing, steering systems, fastening is normal or not, If there is any problem, then stop use until the fully restored
- (2). Clean vehicles please use soft, dry cloth to wipe, can not use water or fuel cleaning, that will lead to corrosion switch and caused switch failure.
- (3). This product cannot store in the high-temperature places or near the fire, or in moist places, The product should be covered in the snowy and rainy days..
- (4). Charge the battery fully if you will store it for a long time, then charge it every 3 month, in this way you can extent the lifetime of the battery.
- (5). Stop using, pls take off the battery from the motorcycle and make the switched on "OFF" position. Also cut off the power. Keep the battery in proper place. Donnot allow children play the battery.
- (6). When maintenance, donnot revise the motorcycle's circuit and structure. The key parts should be maintained and guided by the professional staff.
- (7). Don't recharge the non-rechargeable batteries, don't mix the old and new or different types of batteries. Pay attention to the Positive and negative.
- (8). In the unstable supply voltage region. We recommended to install voltage stabilizer to protect the battery

## 12. Trouble Shooting

The vehicle does not move.

1. Check forward and back switch is in neutral position switch or not. (Middle of the switch is neutral position)
2. Check the power's positive and negative cord is plugged firmly
3. Fuse melted or jump off.
4. Check the charger is plugging into the charging hole or not. If yes, the motorcycle will cut off automatically. After plugging off the charger, then can use.
5. Foot switch or manual button is stuck down then cannot press ?
6. Whether there is debris stuck wheels

The vehicle moves slowly.

1. Whether battery power is sufficient, If so, need timely charge.
2. Whether there is debris stuck wheels
3. Whether the vehicle is overloaded.
4. Whether the charger is broken then the battery cannot be charged.

The battery cannot be fully charged.

1. Check the charger is ok or not. When charging, the charger will be warm is normal.
2. Check the battery is ok or not.
3. Check the charger or the battery connection is loose or not.

## 1. Directory

|                        |       |
|------------------------|-------|
| Before use             | ----- |
| Specification          | ----- |
| Safety Precautions     | ----- |
| Parts                  | ----- |
| Exploded Diagram       | ----- |
| Assembly diagram       | ----- |
| Notice when using      | ----- |
| Fuse                   | ----- |
| Charging method        | ----- |
| Maintenance and repair | ----- |
| Trouble Shooting       | ----- |

## 2. Before use:

Please read carefully before using our product manual, which tells you the detailed installation and correct use, Then can avoid damage and injury caused by improper operation. Particularly important is that it tells you a lot about safety precautions, Please memorize these and guide your child with patience. Please place the instructions in easily accessible place for future reference.

## 3. Specification

|                     |   |               |                           |
|---------------------|---|---------------|---------------------------|
| External dimensions | 116*73*50cm                               | Power Mode    | Rechargeable              |
| User's proper age   | suitable for children around 3-8years old | Charging Spec | 6V 1000mA (or 12V 1000mA) |
| Loading limitation  | 30 KGS                                    | Charging Time | 8-12 hours.               |
| Speed               | 3 km/hr                                   | Power life    | 280 times charging.       |
| Battery Spec        | 6V, 7AH (or 6V, 7AH *2 or 12V 7AH*1)      | Fuse Spec     | Self-resetting fuse       |

#### 4. Cautions For Safety

- (1). The product must be assembled by adults. Before use check whether the adult assemble correctly according to the instructions.
- (2). To avoid injury to small parts, children under 3 years old prohibited.
- (3). Children should stay away from the plastic bags, prevent children from covering the head leading to choking hazard
- (4). When using, Children should wear safety helmets and must be guarded and guided by adults, and not to leave the child alone to avoid accidents.
- (5). The motorcycle is for one person. The maximum weight limited of the motorcycle is 30KG. suitable for over 3 years to 8 years old children, Non-overloading.
- (6). The motorcycle should drive on the flat surface It is prohibited to drive on streets, slopes or any other dangerous places.
- (8). When the motorcycle moving, user should not be free to turn forward, backward switch, After the motorcycle stopped, then can switch the forward and backward switch.
- (9). Do not reverse push and lateral pull the motorcycle in the normal driving to prevent the rollover risk.
- (10). The battery charger to be operated by an adult, do not let children charge the battery.
- (11). Do not directly wash the motorcycle with water or rain the motorcycle. To prevent water damage to the motor circuit
- (12). Adults should check regularly (once every two weeks suggested), wires, plugs, electrical, housing, steering systems, fastening is normal or not, If there is any problem, then stop use until the fully restored.
- (13). The motorcycle battery and the charger is not a separate toy, don't let the children play the battery and charger.
- (14). Please use the matched battery and charger, and a stable charging voltage to ensure safe when charging, and extend battery life.
- (15). Spare parts exchange should be operated by an adult, because the battery is very heavy, and the internal acidic electrolyte, if any leakage should avoid contact with liquid, and need a professional disposition. If accidental contact with the electrolyte, it is timely at least 15 minutes rinse with cold water and seek medical treatment.
- (16). Avoid the short circuit of the power, to prevent the risk of burning.
- (17). This product cannot store in the high-temperature places or near the fire, prevent plastic parts melt, charging away from flammable materials to prevent fires.
- (18). Shall not use the different specifications fuse.
- (19). Don't recharge the non-rechargeable batteries, don't mix the old and new or different types of batteries. Shall not be casually discarded, attention to environmental protection.
- (20). No using or long-term no use the motorcycle, please pull out the battery on the red line, the switch is "off" position, to ensure circuit safety.
- (21). Don't expose the motorcycle to the sun or using the motorcycle in the rainy days.
- (22). Keep the package bags in the proper place for further use because there is important information on it.

#### 9. Fused tube

- The vehicle use self-tapping fuse.
- When overloading or improper use, the fuse will be automatically cut off in 10-20 seconds and then will automatically connect the power.
- To avoid the cutting off, please pay attention:
- (1). The maximum weight limited of the motorcycle is 30KG.
  - (2) Not stall the car running or heavy trailer behind.
  - (3). May not liquid immersion, it may cause the short circuit.
  - (4). Don't revise the vehicle's circuit or the structure.

#### 10. Charging

- (1). Like the below picture, put the charger into the vehicle's charging hole.
- (2). Like the picture, The power plug into the matched stable AC power.

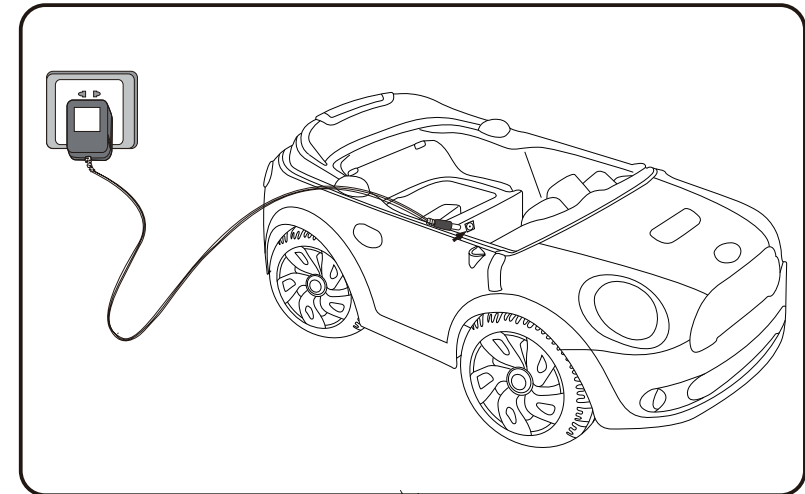

#### Attention when charging:

1. To assure the safety, Adults should do the battery charging,
2. First using, fully charged, need to charge another 8-12 hours.
3. Charge the battery if the vehicle runs slower, can charge 8-12 hours. But cannot charge over 15 hours.
4. Cannot open or decompose the battery and charger, should use the matched charger and battery.
5. When charging, cannot upside down the battery.
6. Before charging, check the charger, battery and the plug is ok or not. If broken, no use. After repaired, then can use.
7. Charge the battery fully if you will store it for a long time, then charge it every 3 months, in this way you can extend the lifetime of the battery.

## 6. Exploded Diagram

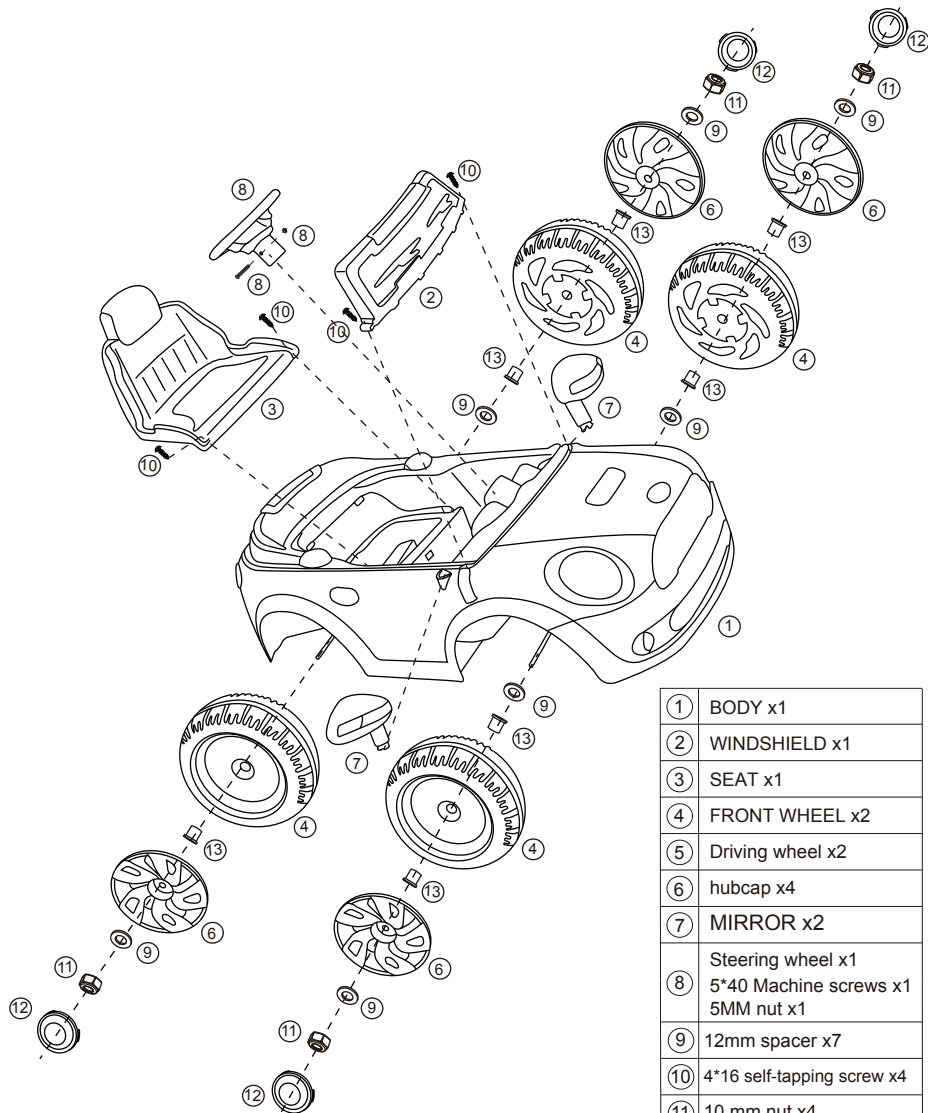

|   |   |
|---|---|
| ① | BODY x1   |
| ② | WINDSHIELD x1   |
| ③ | SEAT x1   |
| ④ | FRONT WHEEL x2  |
| ⑤ | Driving wheel x2  |
| ⑥ | hubcap x4   |
| ⑦ | MIRROR x2   |
| ⑧ | Steering wheel x1<br>5*40 Machine screws x1<br>5MM nut x1 |
| ⑨ | 12mm spacer x7  |
| ⑩ | 4*16 self-tapping screw x4                                |
| ⑪ | 10 mm nut x4  |
| ⑫ | hubcap x4   |
| ⑬ | Insert parts x7   |
| ⑭ | Charger x1  |

## 7. Product Assembly Chart

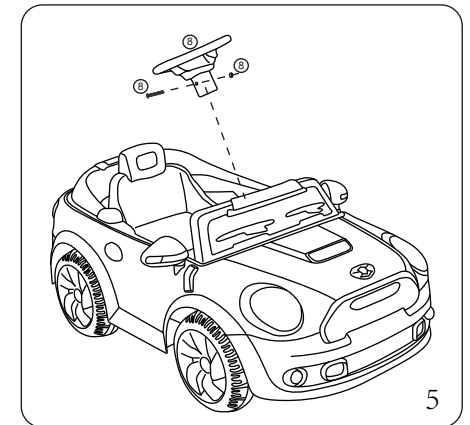
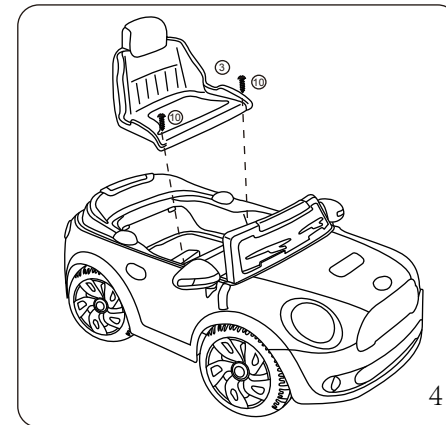
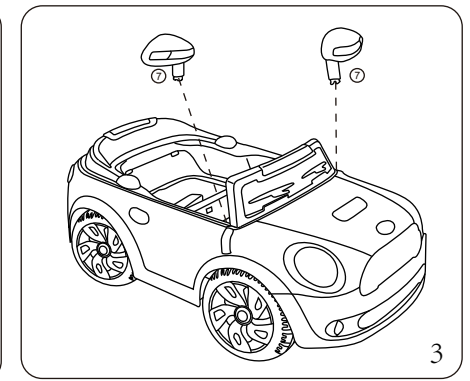
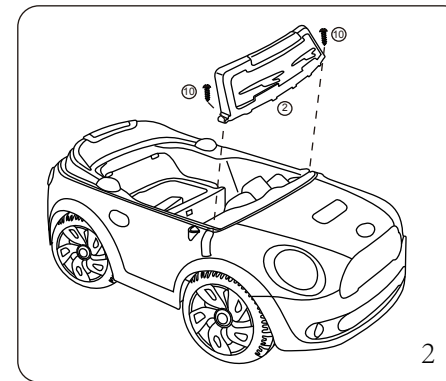
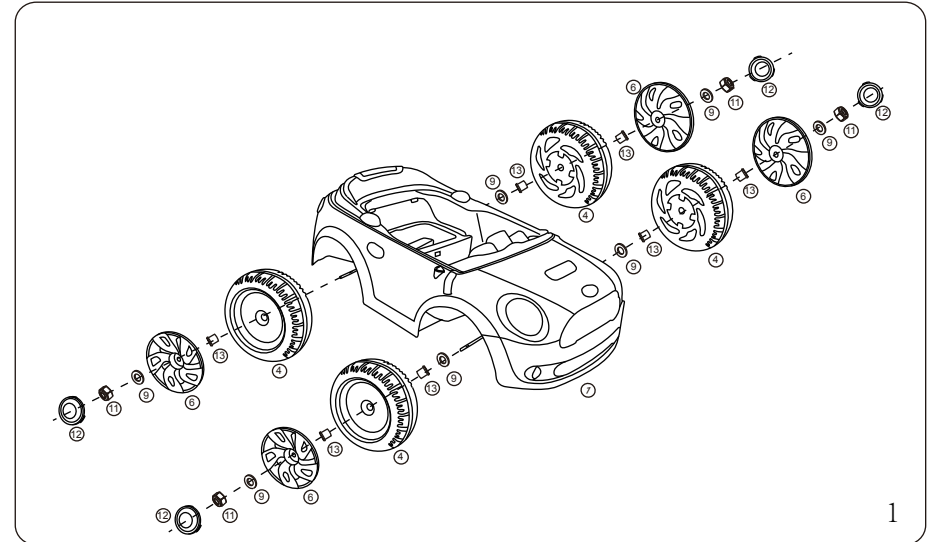

## 8. THE USE OF INFORMATION

- (1). The car has the music and Remote Control function.
- (2). Charge the battery if the vehicle runs slower than normal. Charge the battery for 8-12 hours. But cannot over 15 hours. It is normal that the power charger and the battery become warmer while the battery is on charging.
- (3). The car has these functions: Refer to Picture (1)
  - Function: 1. The car has the foot step function. First, turn on the power, and then step the footstep by foot, the car can drive.
  2. FORWARD/BACKWARD function. Press FORWARD, the car will go front. Press BACKWARD, The car will go back.
  3. The steering wheel has the music and horn function.
  4. The vehicle has the power switch. To use, turn on the power switch. No use, then turn off the power switch.

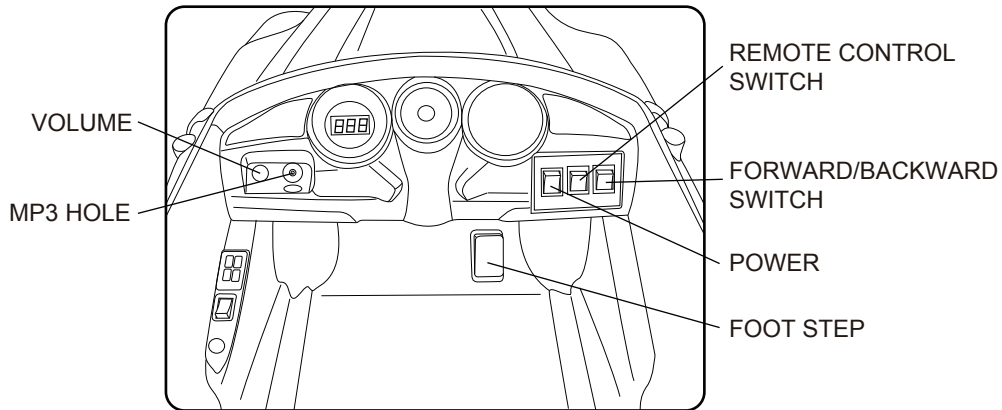

(1)

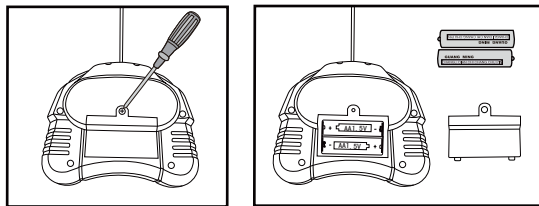

(2)

## 5. PARTS DRAWING

